

ABB MEASUREMENT & ANALYTICS | DATA SHEET

## 266GST and 266AST

Gauge and absolute pressure transmitters



---

# Measurement made easy

Engineered solutions for all applications

---

## Base accuracy

- 0.04 % of calibrated span (optional 0.025 %)

## Proven sensor technology together with state-of-the-art digital technology

- Large turn down ratio of up to 100:1

## Comprehensive selection of sensors

- Optimized performance and stability

## 10-year stability

- 0.15 % of URL

## Flexible configuration options

- Local configuration via keys on LCD indicator

## TTG (Through-The-Glass) key technology

- Enables quick and easy local configuration without the need to open the cover - even in environments with explosion protection

## IEC 61508 certification

- For SIL2 (1oo1) and SIL3 (1oo2) applications

## Full compliance with Pressure Equipment Directive (PED) category III

## Product in compliance with Directive 2011/65/UE (RoHS II)

## In-built advanced diagnostics

## Specification – functional

### Range and span limits

Sensor Code	Upper Range Limit (URL)	Lower Range Limit (LRL) 266GST *	Minimum measuring span	
			266GST	266AST
C	6 kPa	-6 kPa	0.2 kPa	0.3 kPa
	60 mbar	-60 mbar	2 mbar	3 mbar
	24 inH2O	-24 inH2O	0.8 inH2O	2.25 mmHg
F	40 kPa	-40 kPa	0.4 kPa	2 kPa
	400 mbar	-400 mbar	4 mbar	20 mbar
	160 inH2O	-160 inH2O	1.6 inH2O	15 mmHg
L	250 kPa	-100 kPa	2.5 kPa	12.5 kPa
	2500 mbar	-1 bar	25 mbar	125 mbar
	1000 inH2O**	-14.5 psi	0.36 psi	93.8 mmHg
D	1000 kPa	-100 kPa	10 kPa	50 kPa
	10 bar	-1 bar	100 mbar	500 mbar
	145 psi	-14.5 psi	1.45 psi	7.25 psi
U	3000 kPa	-100 kPa	30 kPa	150 kPa
	30 bar	-1 bar	0.3 bar	1.5 bar
	435 psi	-14.5 psi	4.35 psi	21.7 psi
R	10000 kPa	-100 kPa	100 kPa	500 kPa
	100 bar	-1 bar	1 bar	5 bar
	1450 psi	-14.5 psi	14.5 psi	72.6 psi
V	60000 kPa	-100 kPa	600 kPa	-
	600 bar	-1 bar	6 bar	-
	8700 psi	-14.5 psi	87 psi	-

\* Measuring range lower limit (LRL) for 266AST is 0 abs for all measuring ranges

\*\* Measuring range upper limit (URL) for 266GST sensor L is 250 kPa, 2500 mbar or 36.26 psi

### Span limits

Maximum span = URL

For optimum measuring accuracy, it is recommended that you select the sensor code which will provide the lowest TD value.

### Zero position suppression and elevation

The zero position and span can be set to any value within the measuring range limits listed in the table if:

- adjusted span  $\geq$  smallest span

### Damping

Configurable time constant between 0 and 60 s.

This is in addition to the sensor response time.

### Turn On time

Ready for operation as per specifications in less than 10 s with minimum damping.

For DDS the turn on time is 12 s and the Output current during this time is 21 mA.

### Insulation resistance

>100 M $\Omega$  at 500 V DC (between terminals and ground).

## Specification – operative limits

### Pressure limits

#### Overpressure limits

Without damage to the transmitter

Sensors	Overpressure limits
Sensor C, F	0 absolute and 1 MPa, 10 bar, 145 psi
Sensor L	0 absolute and 3 MPa, 30 bar, 435 psi
Sensor D	0 absolute and 6 MPa, 60 bar, 870 psi
Sensor U	0 absolute and 6 MPa, 60 bar, 870 psi
Sensor R	0 absolute and 30 MPa, 300 bar, 4300 psi
Sensor V	0 absolute and 90 MPa, 900 bar, 13050 psi

#### Proof pressure

The transmitter can be subjected to a line pressure up to the following values without leakage:

Sensors	Overpressure limits
Sensor C, F	0 absolute and 1 MPa, 10 bar, 145 psi
Sensor L	0 absolute and 3 MPa, 30 bar, 435 psi
Sensor D	0 absolute and 6 MPa, 60 bar, 870 psi
Sensor U	0 absolute and 6 MPa, 60 bar, 870 psi
Sensor R	0 absolute and 30 MPa, 300 bar, 4300 psi
Sensor V	0 absolute and 90 MPa, 900 bar, 13050 psi

Meets hydrostatic test requirements of ANSI/ISA-S 82.03.

### Temperature limits °C (°F)

#### Environment

This is the operating temperature

Models 266GST, 266AST	Ambient temperature limits
Silicone oil	-40 to 85 °C (-40 to 185 °F)
Fluorocarbon (Galden)	-40 to 85 °C (-40 to 185 °F)
White oil	-6 to 85 °C (21 to 185 °F)
Integral LCD display	-40 to 85 °C (-40 to 185 °F)

LCD display may be affected in visibility below -20°C (-4°F) or above +70°C (+185°F).

Transmitters with ambient temperature limit of -50°C (-58° F) are available through special option.

#### IMPORTANT

For applications in explosive environments, the temperature range specified on the certificate / approval applies dependent upon the degree of protection sought.

#### Process

Models 266GST, 266AST	Process temperature limits
Silicone oil	-50 to 121 °C (-58 to 250 °F)
Fluorocarbon (Galden)	-40 to 121 °C (-40 and 250 °F)
White oil	-6 to 121 °C (21 to 250 °F)

≤ 85 °C (185 °F) for operating pressures below the atmospheric pressure

#### Storage

Models 266GST, 266AST	Storage temperature range
Storage temperature	-50 to 85 °C (-58 to 185 °F)
Integral LCD display	-40 to 85 °C (-40 to 185 °F)
White oil	-6 to 85 °C (21 to 185 °F)

## Limits for environmental effects

### Electromagnetic compatibility (EMC)

Meets requirements of EN 61326 and Namur NE-21 (option)  
Overvoltage strength (with surge protection): 4 kV (in acc. with IEC 1000-4-5 EN 61000-4-5)

### Pressure Equipment Directive (PED)

Meets requirements of Directive 2014/68/EU category III module H.

### Humidity

Relative humidity: Up to 100 %.  
Condensation, icing: Permissible

### Vibration resistance

Acceleration up to 2 g at frequencies of up to 1000 Hz (according to IEC 60068-2-6).  
Acceleration limited to 1 g for housing out of stainless steel.

### Shock resistance

Acceleration: 50 g  
Duration: 11 ms  
(according to IEC 60068-2-27).

### IP rating

In accordance with EN 60529, JIS C0920  
The transmitter is dust and sand proof and protected against immersion effects.

- IP 67, IP 68 **on request**, NEMA 4X
- IP 65 (devices with Harting Han plug connector)
- IP 66 (devices with barrel housing made from aluminum or stainless steel housing)

### Hazardous atmospheres

With or without integral display

#### INTRINSIC SAFETY Ex ia:

- ATEX Europe (code E1) approval  
II 1 G Ex ia IIC T6...T4 Ga, II 1/2 G Ex ia IIC T6...T4 Ga/Gb, II 1 D Ex ia IIIC T85 °C Da, II 1/2 D Ex ia IIIC T85 °C Da; IP66, IP67.
- IECEx (code E8) approval  
Ex ia IIC T6...T4 Ga/Gb, Ex ia IIIC T85 °C Da; IP66, IP67.
- NEPSI China (code EY)  
Ex ia IIC T4/T5/T6 Ga, Ex ia IIC T4/T5/T6 Ga/Gb, Ex iaD 20 T85/T100/T135, Ex iaD 20/21 T85/T100/T135.

#### EXPLOSION PROOF:

- ATEX Europe (code E2) approval  
II 1/2 G Ex db IIC T6 Ga/Gb Ta=-50 °C to +75 °C, II 1/2 D Ex tb IIIC T85 °C Db Ta = -50 °C to +75 °C; IP66, IP67.
- IECEx (code E9) approval  
Ex db IIC T6 Ga/Gb Ta=-50 °C to +75 °C, Ex tb IIIC T85 °C Db Ta = -50 °C to +75 °C; IP66, IP67.
- NEPSI China (code EZ)  
Ex d IIC T6 Gb, Ex tD A21 IP67 T85 °C.

#### INTRINSIC SAFETY Ex ic:

- ATEX Europe (code E3 ) type examination  
II 3 G Ex ic IIC T6...T4 Gc, II 3 D Ex tc IIIC T85 °C Dc; IP66, IP67.
- IECEx (code ER) type examination  
Ex ic IIC T6...T4 Gc, Ex tc IIIC T85 °C Dc; IP66, IP67.
- NEPSI China (code ES) type examination  
Ex ic IIC T4~T6 Gc, Ex tD A22 IP67 T85 °C.

#### FM Approvals US (code E6) and

#### FM Approvals Canada (code E4):

- Explosionproof (US): Class I, Division 1, Groups A, B, C, D; T5
- Explosionproof (Canada): Class I, Division 1, Groups B, C, D; T5
- Dust-ignitionproof: Class II, Division 1, Groups E, F, G, Class III, Division 1; T5
- Flameproof (US): Class I, Zone 1 AEx d IIC T4 Gb
- Flameproof (Canada): Class I, Zone 1 Ex d IIC T4 Gb
- Nonincendive: Class I, Division 2, Groups A, B, C, D T6...T4
- Energy limited (US): Class I, Zone 2 AEx nC IIC T6...T4
- Energy limited (Canada): Class I, Zone 2 Ex nC IIC T6...T4
- Intrinsically safe: Class I, II, III, Division 1, Groups A, B, C, D, E, F, G T6...T4  
Class I, Zone 0 AEx ia IIC T6...T4 (US)  
Class I, Zone 0 Ex ia IIC T6...T4 (Canada)

Type 4X, IP66, IP67 for all above markings.

#### COMBINED FM Approvals US and Canada

- Intrinsically safe (code EA)

#### FM Approvals Canada (code EB):

- Explosionproof (US): Class I, Division 1, Groups A, B, C, D; T5
- Explosionproof (Canada): Class I, Division 1, Groups B, C, D; T5
- Dust-ignitionproof: Class II, Division 1, Groups E, F, G; Class III, Div. 1; T5
- Flameproof (US): Class I, Zone 1 AEx d IIC T4 Gb
- Flameproof (Canada): Class I, Zone 1 Ex d IIC T4 Gb

#### COMBINED ATEX, FM and IECEx Approvals (code EN)

#### Technical Regulations Customs Union EAC (Russia, Kazakhstan, Belarus), Inmetro (Brazil)

The permissible ambient temperature ranges (within the limits of -50 to 85 °C) are specified in the type examination certificates dependent upon the temperature class.

## Specification - electrical data and options

### HART® digital communication and 4 to 20 mA output

Device type: 1a06<sub>hex</sub> (listed with HCF), For DDS 1a93<sub>hex</sub>

#### Power supply

The transmitter operates from 10.5 to 42 V DC (12 to 42 V DC for DDS version) with no load and is protected against reversed polarity (additional loads enable operation above 42 V DC).

During use in Ex ia zones and in other intrinsically safe applications, the power supply must not exceed 30 V DC.

#### Minimum operating voltage

12.3 V DC	Device with the option "S2 – overvoltage protection"
10.8 V DC	Devices with the option "YE – NE21 conformity"

#### Ripple

Max. 20 mV over a 250 Ω load as per HART specifications.

#### Load limitations

Total loop resistance at 4 to 20 mA and HART:

$$R \text{ (k}\Omega\text{)} = \frac{\text{Voltage supply} - \text{Minimum operating voltage (V DC)}}{22 \text{ mA}}$$

A minimum resistance of 250 Ω is required for HART communication.

#### Surge protection (optional)

Up to 4 kV

- Voltage: 1.2 μs rise time / 50 μs delay time at half value
- Current: 8 μs rise time / 20 μs delay time at half value

#### Output signal

Two-wire output 4 – 20 mA, selectable by the operator: linear or square root output signal, characteristic curve with the exponents 3/2 or 5/2, square root for bidirectional flow, linearization table with 22 points (i.e. for level measurements in lateral, cylindrical containers and spherical containers).

The HART communication provides the digital process variables which are superimposed on the 4 to 20 mA signal (protocol in accordance with Bell 202 FSK standard).

#### HART protocol

HART revision 7 (standard, as default)

HART revision 5 (optional, on request) (Not available for DDS).

#### Output current limits (in accordance with NAMUR standard) Overload condition

- Lower limit: 3.8 mA (configurable from 3.8 – 4 mA)
- Upper limit: 20.5 mA (configurable from 20 – 21 mA)

#### Alarm current

##### Adjustment range

Minimum alarm current (low alarm current)	3.6 mA (configurable from 3.6 – 4 mA)
Maximum alarm current (high alarm current)	21 mA (configurable from 20 – 23 mA)
Maximum alarm current (high alarm current) for devices with "HART SIL – functional safety"	Limited to maximum 22 mA! (From electronic version 7.1.15)

#### Standard setting: high alarm current

## FOUNDATION Fieldbus™ output

### Model

Link Active Scheduler (LAS) capability implemented.  
 Manufacturer code: 000320 (hex)  
 Device type code: 0007 (hex)

### Power supply

The transmitter operates from 9 to 32 V DC, regardless of polarity, with or without surge protection.  
 During use in EEx ia zones, the power supply must not exceed 24 V DC (entity certification) or 17.5 V DC (FISCO certification) according to FF-816.

### Current consumption

Operating (quiescent): 15 mA  
 Fault current limit value: 20 mA max.

### Output signal

Physical layer in accordance with IEC 11582 / EN 611582; transmission using Manchester II modulation at 31.25 kbit/s.

### Function blocks/execution period

- 3 enhanced analog input blocks / 25 ms max. (each)
- 1 extended PID block / 40 ms max.
- 1 standard arithmetic block / 25 ms
- 1 standard input selector block / 25 ms
- 1 standard control selector block / 25 ms
- 1 standard signal characterization block / 25 ms
- 1 standard integrator / totalizer block / 25 ms

### Additional blocks

- 1 enhanced resource block
- 1 manufacturer-specific pressure with calibration transducer block
- 1 manufacturer-specific advanced diagnostics transducer block
- 1 manufacturer-specific local display transducer block

### Number of link objects

35

### Number of VCRs

35

### Output interface

FOUNDATION fieldbus digital communication protocol in accordance with standard H1, fulfills the specification V 1.7

### Operating mode during transmitter malfunction

The output signal will be "frozen" to the last value in case of significant transmitter interference, once this interference is detected by the self-diagnostics function (which also displays error states).

In the event of electronics failures or short circuits, the transmitter consumption is electronically limited to a defined value (approx. 20 mA) in order to ensure network safety.

## ...Specification - electrical data and options

### PROFIBUS PA output

#### DeviceType

Pressure transmitter conform with profile 3.0.1  
Indent number: 3450 (hex)

#### Power supply

The transmitter operates from 9 to 32 V DC, independent of the polarity with or without overvoltage protection. During use in EEx ia zones, the operating voltage must not exceed 17.5 V DC. Intrinsically safe installation in accordance with the FISCO model.

#### Input Current

Operation (quiescent current): 15 mA  
Residual current limit value 20 mA maximum

#### Output signal

Physical layer in accordance with IEC 1158-2 / EN 61158-2, transmission with Manchester II modulation with 31.25 kBit/s.

#### Output interface

PROFIBUS PA communication in accordance with PROFIBUS DP 50170 part 2 / DIN 19245 part 1-3

#### Output cycle time

25 ms

#### Data blocks

1 "Physical Block"  
3 "Analog Input" blocks  
1 "Pressure Transducer Block" with calibration  
1 "Transducer Block" local display

#### Operating mode during transmitter malfunction

In case of heavy transmitter errors, which are recognized by self-diagnosis, the output signal can be put into defined states, which can be chosen by the operator: safe, most recent or calculated value.

In case of electronic errors or short-circuits, the current consumption is electronically limited to a set value (approx. 20 mA) for the safety of the network.

### Digital Diaphragm Seal (DDS)



Figure 1 Digital Diaphragm Seal

DDS is the next-gen in differential pressure measurement for ambient-temperature affected installations.

By replacing the oil-filled capillary with electronic cables, DDS leverages data from two independent gauge devices to calculate DP. This technical solution not only zeroes the so called "head-effect" error, but it also takes away the delays in signals driven by traditional measures.

With up to 95% (Versus a traditional solution) faster response time, DDS provides advantages in costs of installation (i.e., simpler mounting) and maintenance (i.e., lower cost due to modular replacements)

#### Main Features

- No oil-based capillary
- Contemporary single-device and combined-devices data
- Independent Primary & Secondary devices
- Modular components' structure
- Single 2-wire 4-20mA loop with single zeroing and calibration
- Opportunity for extra long cabling (up to 150 mt)

## LCD display



M10142

Figure 2 LCD display (example)

### Integral LCD display (code L1)

Wide screen LCD display, 128 x 64 pixel, 52.5 x 27.2 mm (2.06 x 1.07 in), dot matrix, multilingual.

Four buttons for device configuration and management.

Easy setup for quick commissioning.

Customized visualizations which the user can select.

Total value and actual value flow indication.

The display can also be used to show static pressure, sensor temperature, and diagnosis notice, as well as make configuration settings.

### Integral LCD display with TTG–(Through–The–Glass) operation (code L5; not with DDS)

As with the integral LCD display above, but featuring an innovative TTG (Through–The–Glass) button technology which can be used to activate the device's configuration and management menus without having to remove the transmitter housing cover.

The TTG (Through–The–Glass) buttons are protected against accidental activation.

## Specification - measuring accuracy

Reference conditions according to IEC 60770.  
 Ambient temperature 20 °C (68 °F), rel. humidity 65 %, atmospheric pressure 1013 hPa (1013 mbar), measuring span based on zero, separating diaphragms made from stainless steel AISI 316 L, or Hastelloy, silicone oil filling fluid, HART digital trim values equal to 4 and 20 mA span end points, linear characteristic.

Unless otherwise stated, errors are specified as a % of the span value.

Some measuring accuracy levels relating to the upper measuring range limit (URL) are affected by the current turn down (TD); i.e., the ratio of the upper measuring range limit to the set span.

FOR OPTIMUM MEASURING ACCURACY, IT IS RECOMMENDED THAT YOU SELECT THE SENSOR CODE WHICH WILL PROVIDE THE LOWEST TD VALUE.

All specification performance data for DDS version refers to two transmitters (primary and secondary) with identical sensor ranges.

All other performances specifications can be taken as reference of each DDS pressure sensor without correlation to differential pressure compute.

### Dynamic performance (according to IEC 61298-1)

Sensors	Time constant (63.2% of total step response)
Sensor C to V (all)	≤ 150 ms
Reaction time for all sensors	≤ 40 ms

Response time (total) = reaction time + time constant

For GST with DDS

Sensors	Time constant (63.2% of total step response)
Sensor C to V (all)	≤ 150 ms
Reaction time for all sensors	≤ 70 ms

Response time (total) = reaction time + time constant

### Accuracy rating (Elin)

% of calibrated span, consisting of terminal-based non-linearity, hysteresis, and non repeatability.

In the case of fieldbus devices, SPAN refers to the analog input function block output scaling.

Model	Sensors	for TD range	
266GST	C to V	from 1:1 to 10:1	± 0.04 %
	C	from 10:1 to 30:1	± (0.04 + 0.005 x TD - 0.05) %
	F to V	from 10:1 to 100:1	± (0.04 + 0.005 x TD - 0.05) %
	L to R	from 1:1 to 10:1	± 0.025 % (optional)
266AST	C to R	from 1:1 to 10:1	± 0.04 %
	C to R	from 10:1 to 20:1	± (0.04 + 0.005 x TD - 0.05) %

### Accuracy rating for DDS version (Elin)

Accuracy DP rating for DDS version refers to two transmitters with identical sensor range

Model	Sensor	for TD	
266GST	C to V	from 1:1 to 10:1	± 0.06 %

### Ambient Temperature (EΔTz + EΔTs)

Per 20 K change within the limits of -40 to 85 °C (per 36 °F change within the limits of -40 to 185 °F):

Model	Sensors	for TD up to	
266GST	C and F	10:1	± (0.06 % URL + 0.09 % span)
	L to V	10:1	± (0.03 % URL + 0.045 % span)
266AST	C and F	10:1	± (0.06 % URL + 0.09 % span)
	L to R	10:1	± (0.03 % URL + 0.045 % span)

In the case of an ambient temperature change between -10 and 60 °C (14 and 140 °F):

Model	Sensor	for TD up to	
266GST	C and F	10:1	± (0.08 % URL + 0.08 % span)
	L to V	10:1	± (0.06 % URL + 0.06 % span)
266AST	C and F	10:1	± (0.2 % URL + 0.1 % span)
	L to R	10:1	± (0.06 % URL + 0.06 % span)

Per 10 K change within the limits of -40 to -10 °C or 60 to 85 °C (per 18 °F change within the limits of -40 to 14 °F or 140 to 185 °F):

Model	Sensor	for TD up to	
266GST	C and F	10:1	± (0.04 % URL + 0.05 % span)
	L to V	10:1	± (0.03 % URL + 0.045 % span)
266AST	C and F	10:1	± (0.1 % URL + 0.05 % span)
	L to R	10:1	± (0.03 % URL + 0.045 % span)

### Ambient temperature for DDS version (ET)

for an ambient temperature change from -10 °C to +60 °C (+14 to +140 °F):

Model	Sensor	for TD up to	
266GST	C and F	10:1	± 0.08 % URL
	L to V	10:1	± 0.06 % URL

per 10K change between the limits of -40 °C to -10 °C or +60° to +85 °C (per 18 °F change between the limits of -40 to +14 °F or +140° to +185 °F):

Model	Sensor	for TD up to	
266GST	C and F	10:1	± 0.050 % URL
	L to V	10:1	± 0.045 % URL

$$ET_{tot} = \sqrt{(ET_P * URL/100)^2 + (ET_s * URL/100)^2}$$

ET<sub>P</sub> = Temperature Performance Primary device

ET<sub>s</sub> = Temperature Performance Secondary device

### Supply voltage

Within the limit values for the voltage / load, the total influence is less than 0.005 % of the upper measuring range limit per volt.

### Load

Within the load / voltage limits, the total influence is negligible.

### Electromagnetic field

Meets all requirements of EN 61326 and NAMUR NE-21.

### Common-mode interference

No influence from 100 V rms @ 50 Hz, or 50 V DC

### Mounting position

Rotations in the plane of the diaphragm have a negligible effect. A tilt from the vertical of up to 90° causes a zero point shift of up to 0.35 kPa (3.5 mbar, 1.4 inH<sub>2</sub>O), which can be corrected by making an appropriate zero position adjustment. There is no effect on the measuring span. In applications where a dynamic inclined installation is required (e.g. naval applications with maximum vessel inclination of +/-22.5°), the maximum error can be up to 0,5 mbar for 266GST and 2 mbar for 266AST. Such error might be resulting in a deviation from the standard accuracy with percentual magnitude depending on the range of the selected device.

In case of non-dynamic inclined installations, this effect can be eliminated by performing a zero calibration in the field.

Please contact ABB to assess more in details on the installation effects

### Long-term stability

± 0.15 % (±0.25 % for DDS ) of URL over a 10 years period (± 0.05 % (± 0.1 % for DDS) URL/year)

### Total performance

Temperature change of 28 °C (50 °F),  
only 266GST: with base accuracy option D1 (0.025 %)

Model	Sensor	for TD	Total performance
266GST	L to R	1:1	± 0.108 % of calibrated span
266AST	C to R	1:1	± 0.112 % of calibrated span

Within a temperature change range of -10 to 60 °C (14 to 140 °F) (DIN 16086),  
only 266GST: with base accuracy option D1 (0.025 %)

Model	Sensor	for TD	Total performance
266GST	L to R	1:1	± 0.123 % of calibrated span
266AST	C to R	1:1	± 0.126 % of calibrated span

The total performance accuracy includes the measuring error (non-linearity including hysteresis and non repeatability), as well as the thermal change in the ambient temperature as regards the zero signal and span.

$$E_{\text{perf}} = \sqrt{(E_{\Delta Tz} + E_{\Delta Ts})^2 + E_{\text{lin}}^2}$$

$E_{\text{perf}}$  = Total performance

$E_{\Delta Tz}$  = Effect of the ambient temperature on zero

$E_{\Delta Ts}$  = Effect of the ambient temperature on span

$E_{\text{lin}}$  = Accuracy rating (for terminal-based linearity 0.04 %)

### Total performance for DDS version

$$E_{\text{perf}} = \sqrt{(E_{\text{Lin}}^2 + ET_{\text{tot}}^2)}$$

$E_{\text{perf}}$  = Total Performance

$E_{\text{lin}}$  = Accuracy rating

$ET_{\text{tot}}$  = Effect of the ambient temperature

## Specification – physical

(Please refer to the order information to check the availability of different versions of the relevant model)

### Materials

#### Process isolating diaphragms\*

Hastelloy C276; Hastelloy C276, gold plated; stainless steel  
AISI 316L (1.4435)

#### Process connection\*

Stainless steel AISI 316L (1.4404), Hastelloy C276

#### Sensor filling fluid

Silicone oil; fluorocarbon (Galden); white oil (FDA)

#### Mounting bracket\*\*

Barrel version:  
Galvanized C steel with chromium passivation;  
Stainless steel AISI 316L (1.4404)  
DIN version:  
AISI 304 (1.4301)

#### Pressure sensor housing

Stainless steel AISI 316L (1.4404)

#### Electronics housing and cover

Aluminum alloy (copper content  $\leq 0.3\%$ ) with baked epoxy  
finish (color RAL9002); stainless steel AISI 316L.

#### O-ring cover

Buna N

#### Operating element for local zero point, measuring span, and write protection settings

Non-intrusive design (removable) made of glass fiber  
reinforced polypropylene oxide.

#### Plates

- Transmitter name plate: Stainless steel AISI 316 fastened to the electronics housing.
- Certification plate and optional measuring point tag plate / settings plate: Adhesive, fastened to the electronics housing or stainless steel AISI 316L fastened to the electronics housing with rivets or screws.
- Optional tag plate with customer data:  
Stainless steel AISI 316L.

For DDS:

wired-on AISI 316 ss plates for cross identification of  
Primary-Secondary on both devices.

The metal plates are laser engraved, the adhesive signs  
thermo-printed.

For stainless steel housings AISI 316L, the order option I2  
or I3 must be selected for plates made from stainless steel  
AISI 316.

### Calibration

Standard: 0 to measuring range upper limit, for ambient  
temperature and atmospheric pressure  
Optional: To specified measuring span

### Optional extras

#### Mounting bracket

For 60 mm (2 in) pipes or wall mounting

#### LCD display

Can be rotated in 90° increments into 4 positions

#### Additional tag plates

Code I2: For for tag and/or calibration details (up to  
20 characters), in stainless steel, fastened to the  
transmitter housing.

Code I1: For customer data (4 lines of 30 characters each),  
in stainless steel, wired to the transmitter housing

#### Overvoltage protection

- Code S2

#### Cleaning stage for oxygen application (O2)

Code P1

#### Certificates (inspection, implementation, characteristics, material certificate)

Code Cx and Hx

#### Name plate and operating instruction language

Code Tx and Mx

#### Communication plug connector

Code Ux

#### Valve manifold installation

Code A1: Factory installation and pressure test of the ABB  
M26 valve manifold.

\*Transmitter parts that come into contact with fluid

\*\*U-bolt material: stainless steel AISI 400;

screw material: high-strength alloy steel or stainless  
steel AISI 316

## Process connections

1/2 – 14 NPT internal or external thread;  
DIN EN 837-1 G 1/2 B or G 1/2 B (HP) for convex seals; flush diaphragm; for ball valve

## Electrical connections

Two 1/2-14 NPT or M20 x 1.5 threaded bores for cable glands, directly on housing.  
Special communication connector (on request)

- HART: Straight or angled Harting Han 8D connector and one mating plug.
- FOUNDATION fieldbus, PROFIBUS PA: M12 x 1 or 7/8 in plug

## Terminals block

HART version: Three connections for signal / external display, for wire cross sections of up to 2.5 mm<sup>2</sup> (14 AWG), and connection points for testing and communication purposes

Fieldbus versions: Two signal connections (bus connection) for wire cross sections of up to 2.5 mm<sup>2</sup> (14 AWG)

DDS version: three terminals for signal/external meter wiring up to 2.5 mm<sup>2</sup> (14 AWG), also connection points for test and communication purposes. Additional four terminals to connect Primary to Secondary and vice versa.

## Grounding

Internal and external ground terminals are provided for 6 mm<sup>2</sup> (10 AWG) wire cross sections.

## Mounting position

The transmitters can be installed in any position.

The electronic housing can be rotated into any position. A stop is provided to prevent overturning.

## Weight

Approx. 2 kg (4.4 lb); additional 1.5 kg (3.3 lb) for stainless steel housing.

Add 650 g (1.5 lb) for packaging.

## Packaging

Carton with dimensions of 25 x 20 x 14 cm, approx. (10 x 8 x 6 in)

## Specification – configuration

### Transmitter with HART communication and 4 to 20 mA

#### Standard configuration

Transmitters are calibrated at the factory to the customer's specified measuring range. The calibrated range and measuring point number are provided on the name plate. If this data has not been specified, the transmitter will be delivered with the plate left blank and the following configuration:

Physical unit	kPa
4 mA	Zero
20 mA	Measuring range upper limit (URL)
Output	Linear
Damping	1 s
Transmitter interference mode	High alarm
Software tag (max. 8 characters)	Blank
Optional LCD display	PV in kPa; output in mA and in percent as bargraph

Any or all of the configurable parameters listed above - including the lower and upper range values (with the same unit of measurement) - can easily be changed using a portable HART handheld communicator or a PC running the configuration software with the DTM for 266 models. Specifications concerning the flange type and materials, O-ring and vent / drain valve materials, and additional device options are stored in the transmitter database.

#### Tag and Calibration

Tag and/or specific calibrated span can be requested when configuring the device.

Two tag types are available: Short Tag and Long Tag. See below table for details about tag type applicability / presence:

Type	Max Length	On Display	On Certification	On Device Label
Short Tag	8 digits	YES	YES	NO
Long Tag	32 digits	NO	YES	YES

In case no specific indication will be given about the tag type, data will be considered as Long Tag by default. In case tag is required on the optional wired-on customer data plate (optional digits I1, I3) specific indication needs to be given.

On DDS version the Long Tag is used to interconnect the primary and secondary devices and it is not changeable by the User.

#### Customer-specific configuration (option N6)

The following information can be specified in addition to the standard configuration parameters:

Description	16 alphanumeric characters
Supplementary information	32 alphanumeric characters
Date	Day, month, year

For the HART protocol, the following physical units are available for pressure measurements:

Pa, kPa, MPa  
 inH2O @ 4 °C, mmH2O @ 4 °C, psi  
 inH2O @ 20 °C, ftH2O @ 20 °C, mmH2O @ 20 °C  
 inHg, mmHg, Torr  
 g/cm2, kg/cm2, atm  
 mbar, bar

These and others are available for PROFIBUS and FOUNDATION fieldbus.

## Transmitter with PROFIBUS PA communication

### Standard configuration

Transmitters are calibrated at the factory to the customer's specified measuring range. The calibrated range and measuring point number are provided on the name plate. If this data has not been specified, the transmitter will be delivered with the plate left blank and the following configuration:

Measuring profile	Pressure
Physical unit	kPa
Output scale 0 %	Measuring range lower limit (LRL)
Output scale 100 %	Measuring range upper limit (URL)
Output	Linear
Upper alarm limit	Measuring range upper limit (URL)
Upper warning limit	Measuring range upper limit (URL)
Lower warning limit	Measuring range lower limit (LRL)
Lower alarm limit	Measuring range lower limit (LRL)
Hysteresis limit value	0.5 % of output scaling
PV filter time	0 s
Address (set using local control buttons)	126
Measuring point tag	30 alphanumeric characters
Optional LCD display	PV in kPa; output in percent as bargraph display

Any or all of the configurable parameters listed above - including the measuring range values (with the same unit of measurement) - can easily be changed using a PC running the configuration software with the DTM for 266 models. Specifications concerning the flange type and materials, O-ring and vent / drain valve materials, and additional device options are stored in the transmitter database.

### Customer-specific configuration (option N6)

The following information can be specified in addition to the standard configuration parameters:

Description	32 alphanumeric characters
Supplementary information	32 alphanumeric characters
Date	Day, month, year

## Transmitter with FOUNDATION fieldbus communication

### Standard configuration

Transmitters are calibrated at the factory to the customer's specified measuring range. The calibrated range and measuring point number are provided on the name plate. If this data has not been specified, the transmitter will be delivered with the plate left blank and the analog input function block FB1 will be configured as follows:

Measuring profile	Pressure
Physical unit	kPa
Output scale 0 %	Measuring range lower limit (LRL)
Output scale 100 %	Measuring range upper limit (URL)
Output	Linear
Upper alarm limit	Measuring range upper limit (URL)
Upper warning limit	Measuring range upper limit (URL)
Lower warning limit	Measuring range lower limit (LRL)
Lower alarm limit	Measuring range lower limit (LRL)
Hysteresis limit value	0.5 % of output scaling
PV filter time	0 s
Measuring point tag	30 alphanumeric characters
Optional LCD display	PV in kPa; output in percent as bargraph display

The analog input function blocks FB2 and FB3 are each configured for the sensor temperature measured in °C and the static pressure measured in MPa. Any or all of the configurable parameters listed above - including the measuring range values - can easily be changed using a FOUNDATION fieldbus-compatible configuration tool. Specifications concerning the flange type and materials, O-ring and vent / drain valve materials, and additional device options are stored in the transmitter database.

### Customer-specific configuration (option N6)

The following information can be specified in addition to the standard configuration parameters:

Description	32 alphanumeric characters
Supplementary information	32 alphanumeric characters
Date	Day, month, year

### ...Dimensions

(not design data) – dimensions in mm (inch)

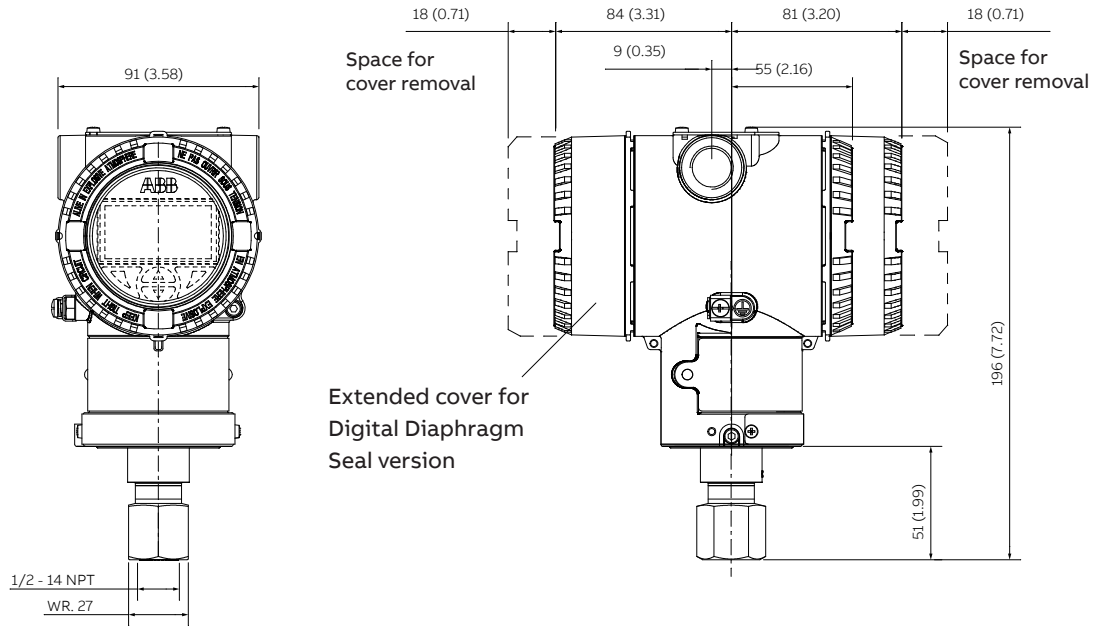

Figure 3 Dimensions - Barrel housing 1/2 NPT female thread



## Electrical connections

### HART version

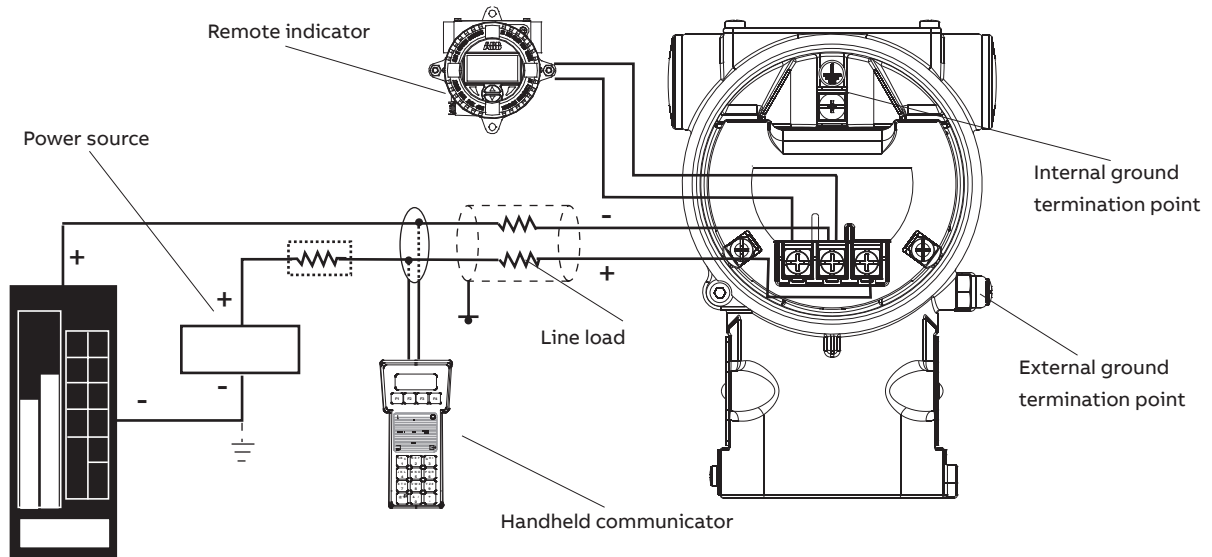

Figure 6 Electrical connection – HART Version

The HART handheld terminal can be connected to any wiring termination point in the loop as long as a minimum resistance of  $250 \Omega$  is present between handheld terminal and transmitter power supply. If it is less than  $250 \Omega$ , additional resistance wires must be installed to enable a communication.

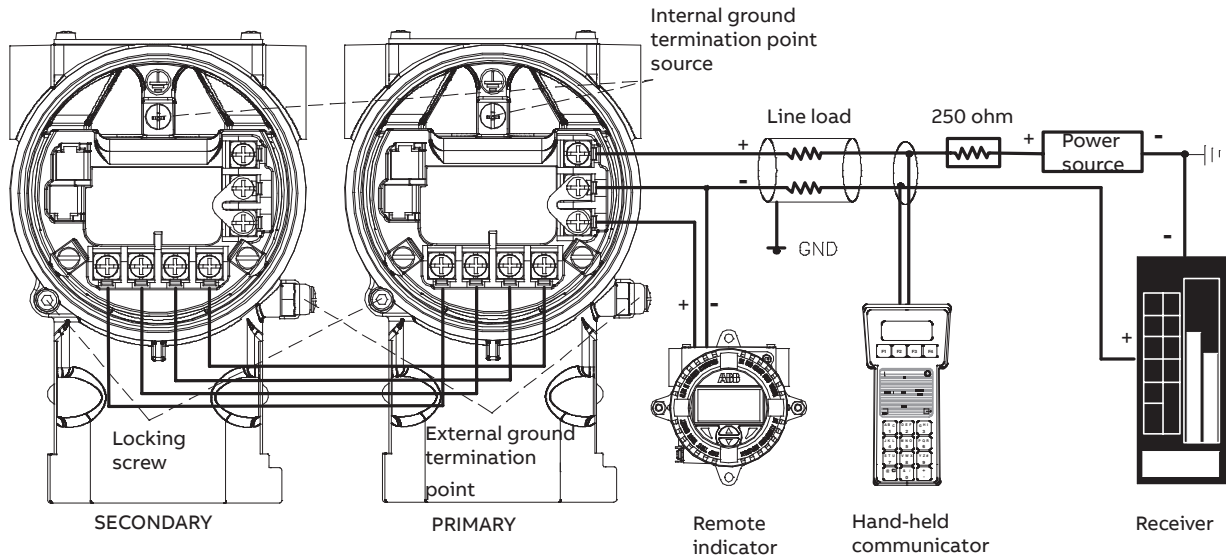

Figure 7 DDS Version

**DDS Entity Parameters**

Here below the cable parameters to be respected when selecting a connection cable to connect primary and the secondary units.

Shielded cable with 4 conductors ( n° 2 twisted pairs)

Temperature range suitable for the application ambient temperature

Compliant with the Hazardous area specifications for Intrinsic Safety and Explosion Proof versions

**CABLE PARAMETERS (maximum allowed)**

	Intrinsic Safety	Explosion Proof	General Purpose
Cc/c [nF]	10	10	10
Cc/s [nF]	20	20	20
Lc [uH]	100	100	100
l [m]	80	50	150

Cc/c = Total cable to cable capacitance;

Cc/S = Total cable to shield capacitance;

Lc = Total cable inductance;

l = cable length;

## ...Electrical connections

### Fieldbus version

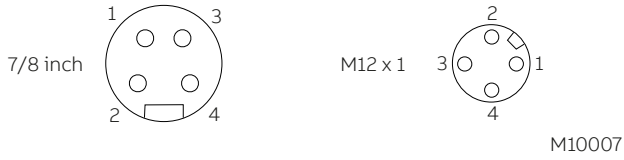

Figure 8 Plug connectors – fieldbus versions

Pin assignment (plug)		
Pin number	FOUNDATION Fieldbus	PROFIBUS PA
1	DATA -	DATA +
2	DATA +	GROUND
3	SHIELD	DATA -
4	GROUND	SHIELD

Delivery scope: plug connector without mating plug (female connector) supplied loose.

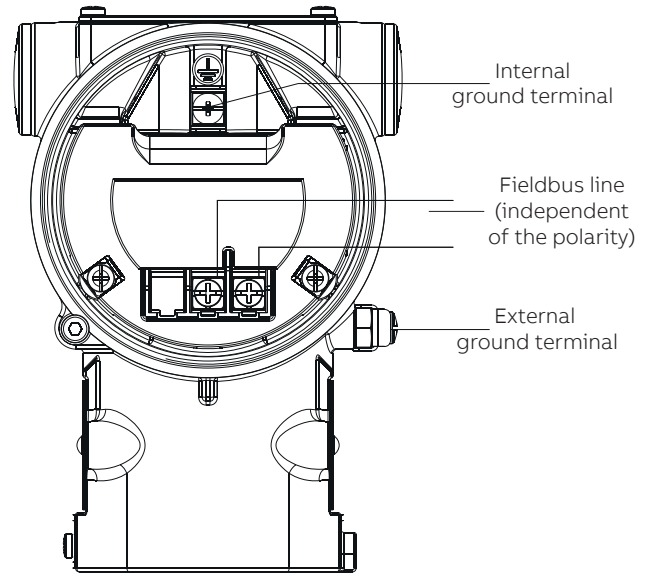

Figure 9 Standard terminal block

### HART version

Mounting indications for connectors (supplied loose)

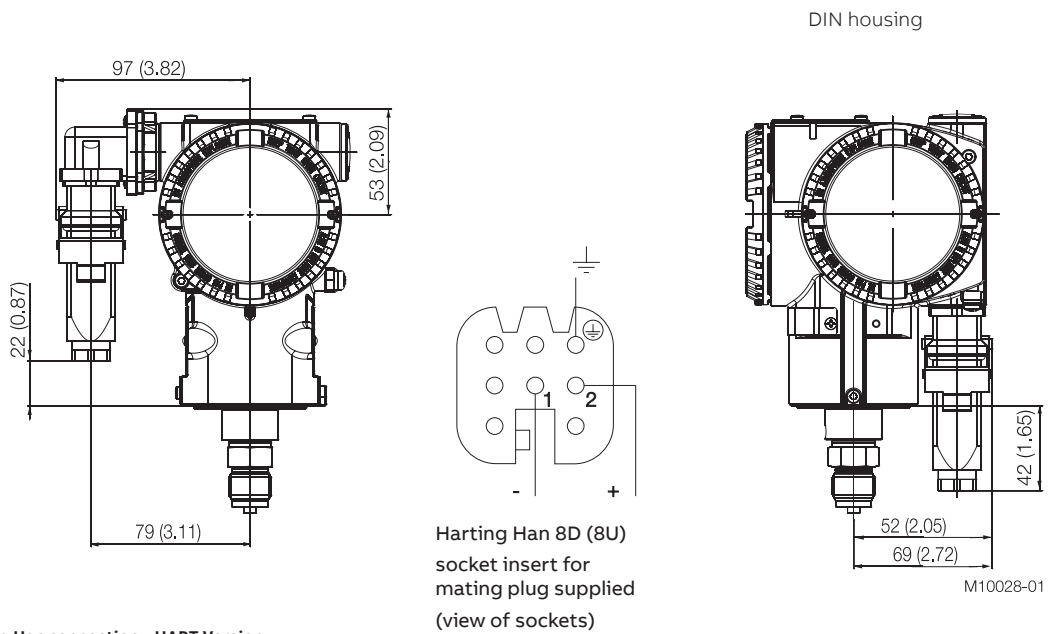

Figure 10 Harting Han connection – HART Version

## Ordering information

### Main ordering information for model 266GST gauge pressure transmitter

Select one or more characters from each category and enter the complete catalog number.

Enter one or more codes for additional order information if you are purchasing optional extras for each transmitter.

Base model - 1st to 6th characters			2 6 6 G S T	X	X	X	X	X	X
<b>Gauge pressure transmitter – Base accuracy 0.04 %</b>									
<b>Sensor Span Limits / overpressure limit – 7th character</b>									
0.2 and 6 kPa	(2 and 60 mbar, 0.8 and 24 inH <sub>2</sub> O)	1 MPa (10 bar, 145 psi)	C						
0.4 and 40 kPa	(4 and 400 mbar, 1.6 and 160 inH <sub>2</sub> O)	1 MPa (10 bar, 145 psi)	F						
2.5 and 250 kPa	(25 and 2500 mbar, 0.36 and 36.26 psi)	3 MPa (30 bar, 435 psi)	L						
10 and 1000 kPa	(0.1 and 10 bar, 1.45 and 145 psi)	6 MPa (60 bar, 870 psi)	D						
30 and 3000 kPa	(0.3 and 30 bar, 4.35 and 435 psi)	6 MPa (60 bar, 870 psi)	U						
100 and 10000 kPa	(1 and 100 bar, 14.5 and 1450 psi)	30 MPa (300 bar, 4350 psi)	R						
600 and 60000 kPa	(6 and 600 bar, 87 and 8700 psi)	90 MPa (900 bar, 13050 psi)	V						
<b>Diaphragm material / filling fluid – 8th character</b>									
Stainless steel AISI 316L (1.4435)	Silicone oil	NACE	S						
Hastelloy® C-276	Silicone oil	NACE	K						
Stainless steel AISI 316L (1.4435)	Fluorocarbon - Galden (suited to oxygen applications)	NACE	A						
Hastelloy® C-276	Fluorocarbon - Galden (suited to oxygen applications)	NACE	F						
Hastelloy® C-276 gold-plated	Silicone oil	NACE (Note 1)	G						
Hastelloy® C-276 gold plated	Fluorocarbon - Galden (suited to oxygen applications)	NACE (Note 1)	E						
Stainless steel AISI 316L (1.4435)	White oil (FDA)	NACE	6						
Hastelloy® C-276	White oil (FDA)	NACE	Z						
<b>Process connection material / type – 9th character</b>									
Stainless steel AISI 316L (1.4404)	1/2 in -14 NPT female	NACE	B						
Stainless steel AISI 316L (1.4404)	DIN EN 837-1 G 1/2 in B	NACE	P						
Stainless steel AISI 316L (1.4404)	G 1/2 in, in front bonded diaphragm	NACE (Note 1)	S						
Stainless steel AISI 316L (1.4404)	1/2 in -14 NPT male	NACE	T						
Stainless steel AISI 316L (1.4404)	DIN EN 837-1 G 1/2 in B	NACE (Note 1)	U						
Stainless steel AISI 316L (1.4404)	For ball valve connection	NACE (Note 2)	V						
Hastelloy® C-276	1/2 in -14 NPT female	NACE	E						
Hastelloy® C-276	DIN EN 837-1 G 1/2 in B	NACE	D						
Hastelloy® C-276	1/2 in -14 NPT male	NACE	K						
<b>Gasket Material – 10th character</b>									
None							N		
<b>Housing Material / Electrical Connection – 11th character</b>									
Aluminium alloy (Barrel type)	1/2 in -14 NPT							A	
Aluminium alloy (Barrel type)	M20 x 1.5							B	
Aluminium alloy (Barrel type)	Harting Han connector					(Note 3)		E	
Aluminium alloy (Barrel type)	Fieldbus connector					(Note 3)		G	
AISI 316L SST (barrel type)	1/2 in -14 NPT (I2 or I3 required)							S	
AISI 316L SST (barrel type)	M20 x 1.5 (I2 or I3 required)							T	
Aluminium alloy (DIN type)	M20 x 1.5							J	
Aluminium alloy (DIN type)	Harting Han connector	(General purpose only)				(Note 3)		K	
Aluminium alloy (DIN type)	Fieldbus connector	(General purpose only)				(Note 3)		W	
AISI 316L SST (barrel type)	Fieldbus connector	(General purpose only)				(Note 3)		Z	
<b>Output – 12th character</b>									
HART digital communication and 4 to 20 mA						(Note 7)			1
PROFIBUS PA						(Note 8)			2
FOUNDATION fieldbus						(Note 8)			3
HART digital communication and 4 to 20 mA, SIL2 and SIL3-certified in acc. with IEC 61508						(Note 7)			8
Digital Diaphragm Seal, 4-20 mA + HART (Mandatory to select one Primary or Secondary device)						(Note 15)			D

## Ordering information

### Additional ordering information for model 266GST gauge pressure transmitter

Add one or more 2-digit code(s) after the basic ordering information to select all required options

	XX	XX	XX	XX
<b>Accuracy</b>				
Base accuracy 0.025%	(Note 4, 17)	D1		
<b>Explosion Protection Certification</b>				
ATEX Intrinsic Safety Ex ia	(Note 9)	E1		
ATEX Explosion Proof Ex db_tb	(Notes 10, 16)	E2		
ATEX Intrinsic Safety Ex ic_tc	(Note 9)	E3		
FM Approvals (Canada) approval (XP, DIP, IS, NI)	(Notes 10)	E4		
FM Approvals (USA) approval (XP, DIP, IS, NI)	(Notes 10)	E6		
FM Approvals (USA and Canada) Intrinsically safe	(Note 9)	EA		
FM Approvals (USA and Canada) Explosionproof	(Notes 10, 16)	EB		
FM Approvals (USA and Canada) Nonincendive	(Note 9)	EC		
Combined ATEX, IECEx and FM Approvals (USA and Canada)	(Notes 10)	EN		
Combined ATEX Ex ia, Ex db_tc and Ex ic_tc	(Notes 10)	EW		
IECEX Intrinsic Safety Ex ia	(Note 9)	E8		
IECEX Explosion Proof Ex db_tb	(Notes 10, 16)	E9		
IECEX Intrinsic Safety Ex ic_tc	(Note 9)	ER		
Combined IEC Approval Ex ia and Ex db_tb	(Notes 10)	EH		
Combined IEC Approval Ex ia, Ex db_tb and Ex ic_tc	(Notes 10)	EI		
NEPSI Intrinsic Safety Ex ia_iaD	(Note 9)	EY		
NEPSI Explosion Proof Ex d_tD	(Notes 10)	EZ		
NEPSI Intrinsic Safety Ex ic_nA_tD	(Note 9)	ES		
Combined NEPSI Ex ia_iaD and Ex d_tD	(Notes 10)	EP		
Combined NEPSI Ex ia_iaD, Ex d_tD and Ex ic_nA_tD	(Notes 10)	EQ		
<b>Other Explosion Protection Certifications</b>				
For TR CU EAC Ex ia for Russia (incl. GOST Metrologic Approval)	(Notes 9, 12)		W1	
For TR CU EAC Ex d for Russia (incl. GOST Metrologic Approval)	(Notes 10, 13)		W2	
For TR CU EAC Ex ia for Kazakhstan (incl. GOST Metrologic Approval)	(Notes 9, 12)		W3	
For TR CU EAC Ex d for Kazakhstan (incl. GOST Metrologic Approval)	(Notes 10, 13)		W4	
For TR CU EAC Ex ia for Belarus (incl. GOST Metrologic Approval)	(Notes 9, 12)		WF	
For TR CU EAC Ex d for Belarus (incl. GOST Metrologic Approval)	(Notes 10, 13)		WG	
Inmetro (Brazil) Ex ia	(Notes 10, 17, 27)		W5	
Inmetro (Brazil) Ex d	(Notes 10, 17, 27)		W6	
Inmetro (Brazil) Ex nL	(Notes 10, 17, 27)		W7	
<b>Integral LCD display</b>				
With integral LCD display				L1
With integral touch screen LCD display (TTG)	(Note 17)			L5



## ...Ordering information

### ...Additional ordering information for model 266GST gauge pressure transmitter

	XX	XX	XX
<b>Material Traceability</b>			
Inspection certificate EN 10204–3.1 of process wetted parts (not for gaskets)	(Note 6)	H3	
Test report EN 10204–2.2 of pressure bearing and process wetted parts (not for gaskets)		H4	
<b>Plug connector</b>			
Fieldbus 7/8 in (Recommended for FOUNDATION Fieldbus, supplied loose, without mating plug)	(Note 27)		U1
Fieldbus M12 x 1 (Recommended for PROFIBUS PA, supplied loose, without mating plug)	(Note 27)		U2
Harting Han 8D (8U), straight entry (supplied loose)	(Note 27)		U3
Harting Han 8D (8U), angle entry (supplied loose)	(Note 27)		U4
Harting Han 7D (supplied loose)	(Note 27)		U5
With cable gland M20 x 1.5 (Plastic, black, supplied loose)	(Note 27)		U8
<b>Housing accessories</b>			
Manifold mounting and pressure test (NOT AVAILABLE WITH OXYGEN SERVICE CLEANING - PREPARATION PROCEDURE CODE P1)			A1

Note 1: Not available with sensor span limits / overpressure limit Code C, F

Note 2: Not available with sensor span limits / overpressure limit Code C, F, V

Note 3: Select connector with additional order code

Note 4: Only available with sensor span limits / overpressure limit Code L, D, U, R

Note 5: Not available with Output code 2, 3

Note 6: Minor parts with factory certificate according to EN 10204

Note 7: Not available with housing material / electrical connection code G, W, Z

Note 8: Not available with housing material / electrical connection code E, K

Note 9: Not available with housing material / electrical connection code E, G, K, W, Z

Note 10: Not available with housing material / electrical connection code E, G, J, K, W, Z

Note 11: Not available with Hazardous area certification code E4, E6, EA, EB, EC, EN, EY, EZ, ES, EP, EQ, W1, W2, W3, W4, WF, WG

Note 12: The ambient temperature lower limit is -55 degrees C

Note 13: The ambient temperature lower limit is -52 degrees C

Note 14: Not available with option code YE

Note 15: Not available with Housing code J. Not available with Mounting bracket codes B6, B7. Not available with Hazardous area certifications except E2, EB and E9. Not available with Other hazardous area certifications codes and Approvals

Note 16: Available with Output codes D only if combined with Housing codes S, T

Note 17: Not available with Output codes D

Note 18: Only available with Output codes D

Note 19: Not available with Configuration codes NH, NS, NF, NG

Note 20: Not available with Configuration codes NH,NS,NM,NG

Note 21: Not available with Configuration codes NH,NM,NF,NG,N2,N3,N4,N5

Note 22: Not available with Configuration codes NH,NS,NF,NM,N2,N3,N4,N5

Note 23: Not available with Display code L5

Note 24: Not available with any Display codes

Note 25: Not available with Configuration codes NS,NG

Note 26: Not available with Accuracy code D1

Note 27: Not available with any Hazardous area certification codes Ex or Wx

#### Standard delivery scope (changes possible with additional ordering code)

- For standard applications (without explosion protection)
- No display, no mounting bracket, no surge protection
- Multilanguage short-form operating instruction and English labeling
- Configuration with kPa and °C units
- No test, inspection, or material certificates

Unless otherwise specified prior to manufacture, the customer shall be responsible for selecting suitable wetted parts and an appropriate filling fluid in order to ensure compatibility with the measuring fluid.

Compliance with the NACE regulation is based on recommendations MR0175 / ISO 15156. Additionally, stainless steel AISI 316, AISI 316L and Hastelloy C-276 automatically meet the criteria of MR0103, provided that they also meet the criteria of MR0175.

## Ordering information

### Main ordering information for model 266AST absolute pressure transmitter

Select one or more characters from each category and enter the complete catalog number.

Enter one or more codes for additional order information if you are purchasing optional extras for each transmitter.

Base model - 1st to 6th characters				266AST	X	X	X	X	X	X
<b>Absolute pressure transmitter – Base accuracy 0.04 %</b>										
<b>Sensor Span Limits / overpressure limit – 7th character</b>										
0.3 and 6 kPa	(3 and 60 mbar, 2.25 and 45 mmHg)		1 MPa (10 bar, 145 psi)		C					
2 and 40 kPa	(20 and 400 mbar, 15 and 300 mmHg)		1 MPa (10 bar, 145 psi)		F					
12.5 and 250 kPa	(125 and 2500 mbar, 98.3 and 1875 mmHg)		3 MPa (30 bar, 435 psi)		L					
50 and 1000 kPa	(0.5 and 10 bar, 7.25 and 145 psi)		6 MPa (60 bar, 870 psi)		D					
150 and 3000 kPa	(1.5 and 30 bar, 21.7 and 435 psi)		6 MPa (60 bar, 870 psi)		U					
500 and 10000 kPa	(5 and 100 bar, 72.5 and 1450 psi)		30 MPa (300 bar, 4350 psi)		R					
<b>Diaphragm material / filling fluid – 8th character</b>										
Stainless steel AISI 316L (1.4435)	Silicone oil	NACE			S					
Hastelloy® C-276	Silicone oil	NACE			K					
Stainless steel AISI 316L (1.4435)	Fluorocarbon - Galden (suited to oxygen applications)	NACE			A					
Hastelloy® C-276	Fluorocarbon - Galden (suited to oxygen applications)	NACE			F					
Hastelloy® C-276 gold-plated	Silicone oil	NACE (Note 1)			G					
Hastelloy® C-276 gold plated	Fluorocarbon - Galden (suited to oxygen applications)	NACE (Note 1)			E					
Stainless steel AISI 316L (1.4435)	White oil (FDA)	NACE			6					
Hastelloy® C-276	White oil (FDA)	NACE			Z					
<b>Process connection material / type – 9th character</b>										
Stainless steel AISI 316L (1.4404)	1/2 in -14 NPT female	NACE					B			
Stainless steel AISI 316L (1.4404)	DIN EN 837-1 G 1/2 in B	NACE					P			
Stainless steel AISI 316L (1.4404)	G 1/2 in, in front bonded diaphragm	NACE (Note 1)					S			
Stainless steel AISI 316L (1.4404)	1/2 in -14 NPT male	NACE					T			
Hastelloy® C-276	1/2 in -14 NPT female	NACE					E			
Hastelloy® C-276	DIN EN 837-1 G 1/2 in B	NACE					D			
Hastelloy® C-276	1/2 in -14 NPT male	NACE					K			
<b>Gasket Material – 10th character</b>										
None									N	
<b>Housing Material / Electrical Connection – 11th character</b>										
Aluminium alloy (Barrel type)	1/2 in -14 NPT									A
Aluminium alloy (Barrel type)	M20 x 1.5									B
Aluminium alloy (Barrel type)	Harting Han connector	(Note 2)								E
Aluminium alloy (Barrel type)	Fieldbus connector	(Note 2)								G
Stainless steel (barrel type)	1/2 in -14 NPT (I2 or I3 required)									S
Stainless steel (barrel type)	M20 x 1.5 (I2 or I3 required)									T
Aluminium alloy (DIN type)	M20 x 1.5									J
Aluminium alloy (DIN type)	Harting Han connector	(General purpose only)	(Note 2)							K
Aluminium alloy (DIN type)	Fieldbus connector	(General purpose only)	(Note 2)							W
Stainless steel (barrel type)	Fieldbus connector	(General purpose only)	(Note 2)							Z
<b>Output – 12th character</b>										
HART digital communication and 4 to 20 mA				(Note 5)						1
PROFIBUS PA				(Note 6)						2
FOUNDATION fieldbus				(Note 6)						3
HART digital communication and 4 to 20 mA, SIL2 and SIL3-certified in acc. with IEC 61508				(Note 5)						8

## ...Ordering information

Additional ordering information for model 266AST absolute pressure transmitter

	XX	XX	XX
<b>Explosion Protection Certification</b>			
ATEX Intrinsic Safety Ex ia	(Note 7)	E1	
ATEX Explosion Proof Ex db_tb	(Note 8)	E2	
ATEX Intrinsic Safety Ex ic_tc	(Note 7)	E3	
FM Approvals (Canada) approval (XP, DIP, IS, NI)	(Note 8)	E4	
FM Approvals (USA) approval (XP, DIP, IS, NI)	(Note 8)	E6	
FM Approvals (USA and Canada) Intrinsically safe	(Note 7)	EA	
FM Approvals (USA and Canada) Explosionproof	(Note 8)	EB	
FM Approvals (USA and Canada) Nonincendive	(Note 7)	EC	
Combined ATEX, IECEx and FM Approvals (USA and Canada)	(Note 8)	EN	
Combined ATEX Ex ia, Ex db_tc and Ex ic_tc	(Note 8)	EW	
IECEX Intrinsic Safety Ex ia	(Note 7)	E8	
IECEX Explosion Proof Ex db_tb	(Note 8)	E9	
IECEX Intrinsic Safety Ex ic_tc	(Note 7)	ER	
Combined IEC Approval Ex ia and Ex db_tb	(Note 8)	EH	
Combined IEC Approval Ex ia, Ex db_tb and Ex ic_tc	(Note 8)	EI	
NEPSI Intrinsic Safety Ex ia_iaD	(Note 7)	EY	
NEPSI Explosion Proof Ex d_tD	(Note 8)	EZ	
NEPSI Intrinsic Safety Ex ic_nA_tD	(Note 7)	ES	
Combined NEPSI Ex ia_iaD and Ex d_tD	(Note 8)	EP	
Combined NEPSI Ex ia_iaD, Ex d_tD and Ex ic_nA_tD	(Note 8)	EQ	
<b>Other Explosion Protection Certifications</b>			
For TR CU EAC Ex ia for Russia (incl. GOST Metrologic Approval)	(Note 7, 11)		W1
For TR CU EAC Ex d for Russia (incl. GOST Metrologic Approval)	(Note 8, 12)		W2
For TR CU EAC Ex ia for Kazakhstan (incl. GOST Metrologic Approval)	(Note 7, 11)		W3
For TR CU EAC Ex d for Kazakhstan (incl. GOST Metrologic Approval)	(Note 8, 12)		W4
For TR CU EAC Ex ia for Belarus (incl. GOST Metrologic Approval)	(Note 7, 11)		WF
For TR CU EAC Ex d for Belarus (incl. GOST Metrologic Approval)	(Note 8, 12)		WG
Inmetro (Brazil) Ex ia	(Notes 8, 14)		W5
Inmetro (Brazil) Ex d	(Notes 8, 14)		W6
Inmetro (Brazil) Ex nL	(Notes 8, 14)		W7
<b>Integral LCD display</b>			
With integral LCD display			L1
With integral touch screen LCD display (TTG)			L5



## ...Ordering information

### ...Additional ordering information for model 266AST absolute pressure transmitter

	XX	XX	XX	XX
<b>Approvals</b>				
Metrologic Pattern for Russia (NOT APPLICABLE WITH ANY HAZARDOUS AREA CERTIFICATION)	Y1			
Metrologic Pattern for Kazakhstan (NOT APPLICABLE WITH ANY HAZARDOUS AREA CERTIFICATION)	Y2			
Metrologic Pattern for Belarus (NOT APPLICABLE WITH ANY HAZARDOUS AREA CERTIFICATION)	Y4			
CRN (Canadian Registration Number OF14838.5C)	YR			
DNV GL approval (Notes 3, 13)	YA			
Conformity to NAMUR NE 021 (2004) (NOT APPLICABLE WITH SURGE PROTECTOR CODE "S2") (Note 3, 9)	YE			
American Bureau of Shipping (ABS) (Note 3, 13)	YS			
Lloyd's Register Group Ltd. (LR) approval (Note 3, 13)	YB			
Combined Naval approvals (DNV / ABS / LLR) (Note 3, 13)	YM			
<b>Material Traceability</b>				
Inspection certificate EN 10204-3.1 of process wetted parts (not for gaskets) (Note 4)			H3	
Test report EN 10204-2.2 of pressure bearing and process wetted parts (not for gaskets)			H4	
<b>Plug connector</b>				
Fieldbus 7/8 in (Recommended for FOUNDATION Fieldbus, supplied loose, without mating plug) (Note 14)				U1
Fieldbus M12 x 1 (Recommended for PROFIBUS PA, supplied loose, without mating plug) (Note 14)				U2
Harting Han 8D (8U), straight entry (supplied loose) (Note 14)				U3
Harting Han 8D (8U), angle entry (supplied loose) (Note 14)				U4
Harting Han 7D (supplied loose) (Note 14)				U5
With cable gland M20 x 1.5 (Plastic, black, supplied loose) (Note 14)				U8
<b>Housing accessories</b>				
Manifold mounting and pressure test (NOT AVAILABLE WITH OXYGEN SERVICE CLEANING - PREPARATION PROCEDURE CODE P1)				A1

Note 1: Not available with measuring range limits Code C, F

Note 2: Select connector with additional order code

Note 3: Not available with Output code 2, 3

Note 4: Minor parts with factory certificate according to EN 10204

Note 5: Not available with housing material / electrical connection code G, W, Z

Note 6: Not available with housing material / electrical connection code E, K

Note 7: Not available with housing material / electrical connection code E, G, K, W, Z

Note 8: Not available with housing material / electrical connection code E, G, J, K, W, Z

Note 9: Not available with Hazardous area certification code E4, E6, EA, EB, EC, EN, EY, EZ, ES, EP, EQ, W1, W2, W3, W4, WF, WG

Note 10: Not available with sensor C, if calibrated at TD higher than 2

Note 11: The ambient temperature lower limit is -55 degrees C

Note 12: The ambient temperature lower limit is -52 degrees C

Note 13: Not available with option code YE

Note 14: Not available with any Hazardous area certification codes Ex or Wx

### Standard delivery scope (changes possible with additional ordering code)

- For standard applications (without explosion protection)
- No display, no mounting bracket, no surge protection
- Multilanguage short-form operating instruction and English labeling
- Configuration with kPa and °C units
- No test, inspection, or material certificates

Unless otherwise specified prior to manufacture, the customer shall be responsible for selecting suitable wetted parts and an appropriate filling fluid in order to ensure compatibility with the measuring fluid.

Compliance with the NACE regulation is based on recommendations MR0175 / ISO 15156. Additionally, stainless steel AISI 316, AISI 316L and Hastelloy C-276 automatically meet the criteria of MR0103, provided that they also meet the criteria of MR0175.

**Trademarks**

- ® Buna-N is a registered trademark of DuPont Dow Elastomers.
- ® FOUNDATION Fieldbus is a registered trademark of FieldComm Group, Austin, Texas, USA
- ® HART is a registered trademark of FieldComm Group, Austin, Texas, USA
- ® Hastelloy is a registered trademark of Haynes International, Inc.
- ® PROFIBUS and PROFIBUS PA are registered trademarks of PROFIBUS & PROFINET International (PI)
- ™ FieldComm Group is a trademark of FieldComm Group, Austin, Texas, USA
- ™ Galden is a Montefluos trademark
- ™ Kynar is an Elf Atochem North America Inc. trademark
- ™ Viton is a DuPont de Nemours trademark

---

**Notes**

---

## Notes

---

## ABB Measurement & Analytics

For your local ABB contact, visit:  
[www.abb.com/contacts](http://www.abb.com/contacts)

For more product information, visit:  
[www.abb.com/pressure](http://www.abb.com/pressure)

We reserve the right to make technical changes or modify the contents of this document without prior notice. With regard to purchase orders, the agreed particulars shall prevail. ABB does not accept any responsibility whatsoever for potential errors or possible lack of information in this document.

We reserve all rights in this document and in the subject matter and illustrations contained therein. Any reproduction, disclosure to third parties or utilization of its contents – in whole or in parts – is forbidden without prior written consent of ABB.