

SmartLine Manifolds Specification

34-ST-03-149, December 2023



Introduction

- Honeywell SmartLine Manifolds are a perfect compliment to SmartLine Pressure transmitters to provide factory tested, calibrated and certified equipment for accurate, reliable and safe measurement in process applications.
- Available for entire range of SmartLine Pressure Transmitters.
- Block and Bleed models for in-line transmitters.
- 2, 3 and 5-valve manifold configurations for dual head AP, GP and DP transmitters.
- Wide and compact body styles.
- Traditional and wafer style variants.
- Available in various materials including NACE compliant materials of construction.
- Every unit is factory leak tested.
- Available with manifold mounting brackets.
- Factory integration option with transmitter for hassle-free experience.
- Various certification options.
- Full material traceability.



6000 psi Pressure Version

PTFE

- Maximum pressure 413 bar (6000 psi) at -40 to 100°C (212°F).
- Maximum pressure 206 bar (3000 psi) at 215°C (420°F).

Graphite

- Maximum pressure 250 bar (3625 psi) at -40 to 100°C (212°F).
- Maximum pressure 155 bar (2250 psi) at 450°C (842°F).

Salient Features

Dual Grade as Standard

- All stainless steel SmartLine manifolds in stainless steel are SS 316/316L dual-grade certified. All non-wetted components are SS316/316L.

Safety Assured

- Each manifold model is designed to withstand a destructive test of 4 x "Over Pressure" (per ASME VIII, B31.1, B31.3 standards) to ensure reliable and safer operations in the field.

User Friendly Design

- The T-bar on valve heads has a hidden screw to enable smooth and hassle-free operation of valves.
- Well-designed handles for effortless valve operation.
- Ergonomic valve head placements to avoid "pinching fingers".

Honeywell SmartLine Manifolds are offered in two functionally equivalent options "X" and "Z" on the model selection guide.

The Valvehead Design

Preference X

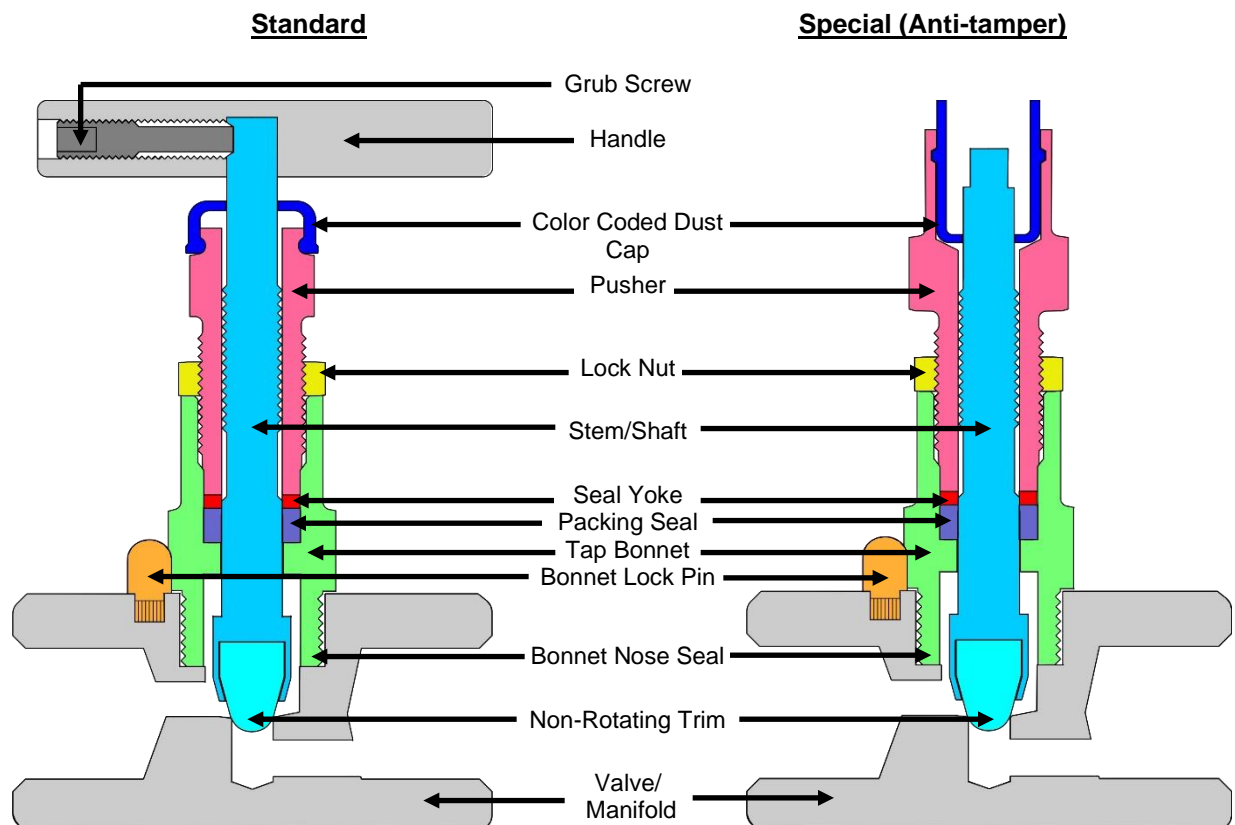

- Low Operating Torque.
- Safety Back Seating of Stem.
- Anti Blow-Out Shaft.
- Stem Seal below the Threads.
- Bonnet Seal located below Threads.
- External adjustment of packing seal.

- Non-Rotating Trim.
- Color Coded Valve Function.
- Hidden Tap Handle Locating Screw.
- Full Traceability.
- Lock Nut.

- Bonnet Lock Pin.
- Stem dust cap.
- Mirror Finish Burnished Stem Seal Surface.
- Single Point Machined Threads.
- Tap Assembly Tracker Code.

The Valvehead Design

Preference Z

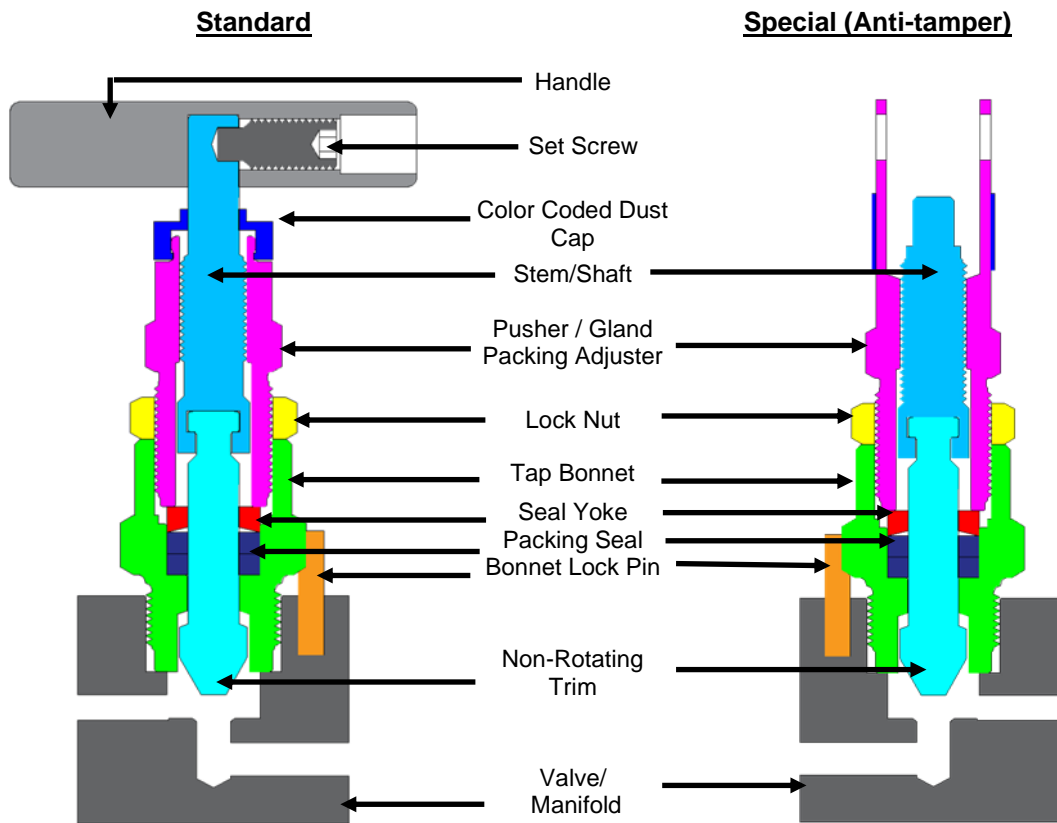

- Low Operating Torque.
- Safety Back Seating of Stem.
- Anti Blow-Out Shaft.
- Stem Seal below the Threads.
- Bonnet Seal located below Threads.
- External adjustment of packing seal.
- Non-Rotating Trim.
- Color Coded Valve Function.
- Hidden Tap Handle Locating Screw
- Full Traceability.
- Lock Nut.
- Bonnet Lock Pin.
- Stem dust cap (only on standard valvehead).
- Mirror Finish Burnished Stem Seal Surface.
- Single Point Machined Threads.
- Tap Assembly Tracker Code.

Features and Benefits Explained

Safety Back Seating of Stem

This function prevents accidental removal of the stem while in operation. When the tap is in the fully opened position the stem produces a metal to metal secondary back seal, removing continuous pressure from the packing.

Anti Blow-Out Shaft

Reduces risk of injury as the shaft will be contained in the unlikely event of a shaft thread failure due to unforeseen circumstances.

Stem Seal below the Threads

This isolates the stem threads from the process media, preventing thread corrosion and keeps solids from entering the thread area which can cause galling. It also isolates the thread lubricant from the process, preventing process contamination as well as lubricant washout.

Bonnet Seal located below Threads

A metal to metal seal is utilized to provide a positive seal that maintains its effectiveness even at high temperatures. This seal is located below the bonnet threads isolating them from the process media.

Bonnet Lock Pin

All taps are secured by a Bonnet lock pin. These pins are machined from billet rather than using a roll pin. The result is a shouldered bonnet lock pin that is knurled on the insertion point.

Non-Rotating Trim

This stops galling or damage to the seat face by not allowing the trim to rotate while lifting off, and seating down on, the seating surface. For added security the trim is produced from billet rather than using a sphere (pure ball) as a ball does not have polarity. This ensures the trim can only rotate around the same axis as the stem.

Single Point Machined Threads

Produces high accuracy threads as opposed to tapping.

100% Pressure Tested

Each manifold is tested with nitrogen gas to a minimum of 750 psi. Hydrostatic testing at 1.5 x MAWP is also available as an option.

External adjustment of packing seal

The stem seal can be easily adjusted insitu, without any disassembly of the valve or manifold.

Stem dust cap

Protects stem threads against contaminants in the atmosphere.

Color Coded Valve Function

Tap function easily identifiable through color coded dust caps.

Full Traceability

All components are fully traceable back to source.

Locknut

Ensures safe operation under high vibration conditions.

Seal Yoke

The high precision yoke provides good encapsulation and integrity of the stem seal.

Hidden Tap Handle Locating Screw

This improves the feel to the user when operating the tap as there are no sharp edges or protruding bolts.

Mirror Finish Burnished Stem Seal Surface

The face where the seal contacts the stem is burnished to a mirror like finish. This reduces operating torque and extends the life of the seal.

Tap Assembly Tracker Code

All taps are assembled with a tracker code to ensure 100% traceability.

Valvehead Materials

Preference X

All wetted components of the valvehead are produced from the same material grade as the manifold body. When special alloys are used, the non-wetted components will be produced from 316/316L SS. Below is a list of a few common materials to illustrate the list of materials used. Care should be taken to specify the correct material for the process media and conditions.

Manifolds Body Material of Construction										
Valvehead Component	SS 316/316L Dual Certified				Hastelloy® C-276	Duplex stainless steel W Nr: 1.4462	Inconel 625	Monel® 400	Carbon Steel (ASTM A105)	
Bonnet	SS 316/316L Dual Certified	Hastelloy® C-276	SS 316/316 L Dual Certified	SS 316/316 L Dual Certified	Hastelloy® C-276	Duplex stainless steel W Nr: 1.4462	Hastelloy® C-276	Inconel 625	Monel® 400	CS (ASTM A105)
Shaft/Stem			Hastelloy® C-276	Monel® 400	Hastelloy® C-276					SS 304
Trim			Hastelloy® C-276	Monel® 400	Hastelloy® C-276					SS 304 Tungsten Carbide Ball
Pusher	SS 316/316L Dual Certified								CS (ASTM A105)	
Yoke									CS (ASTM A105)	
Handle									CS (ASTM A105)	
Grub Screw									SS 304	
Bonnet Lock Pin									SS 304	
Lock Nut									SS 304	
Dust Cap									UV Stabilized Nylon - Color Coded	
Packing Seal	PTFE or Graphite									
Manifold Mounting Bracket	Available as an option in Carbon Steel or SS 316 for all manifolds, suitable for 2" pipe mounting									

	Process wetted components
	Non-wetted components
	Manifold Mounting Bracket

* Monel® 400 or UNS N04400.

** Hastelloy® C-276 or UNS N10276.

Valvehead Materials

Preference Z

All wetted components of the valvehead are produced from the same material grade as the manifold body. When special alloys are used, the non-wetted components will be produced from 316/316L SS or 304/304L SS. Below is a list of a few common materials to illustrate the list of materials used. Care should be taken to specify the correct material for the process media and conditions.

Manifolds Body Material of Construction										
Valvehead Component	SS 316/316L Dual Certified				Hastelloy® C-276	Duplex stainless steel UNS S31803/S32205		Inconel 625	Monel® 400	Carbon Steel (ASTM A105)
Bonnet	SS 316/316L Dual Certified	Hastelloy® C-276	SS 316/316 L Dual Certified	SS 316/316 L Dual Certified	Hastelloy® C-276	Duplex stainless steel UNS S31803/S32205	Hastelloy® C-276	Inconel 625	Monel® 400	CS (ASTM A108)
Trim			Hastelloy® C-276	Monel® 400						SS 316/316L with Tungsten Carbide Ball
Shaft/Stem	SS 316/316L Dual Certified									SS 316/316L Dual Certified
Pusher										CS (ASTM A108)
Yoke										CS /SS 316
Handle										CS (ASTM A108/105)
Grub Screw	SS 304/304L									CS (ASTM A108)
Bonnet Lock Pin										CS
Lock Nut										CS (ASTM A108)
Dust Cap	UV Stabilized Nylon - Color Coded									
Packing Seal	PTFE or Graphite									
Manifold Mounting Bracket	Available as an option in Carbon Steel or SS 316 for all manifolds, suitable for 2" pipe mounting									

	Process wetted components
	Non-wetted components
	Manifold Mounting Bracket

* Monel® 400 or UNS N04400.

** Hastelloy® C-276 or UNS N10276.

Pressure / Temperature Ratings

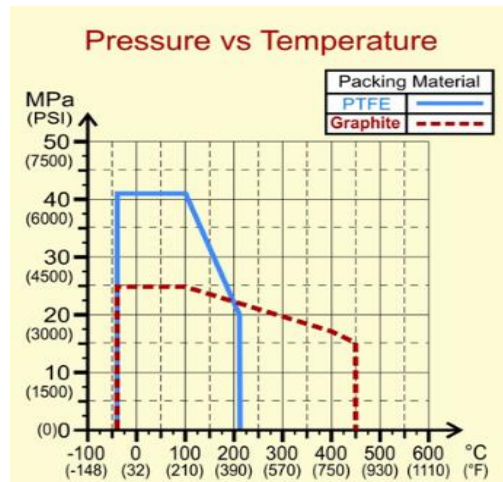

6000 psi Pressure Version (Standard)

PTFE

- Maximum pressure 413 bar (6000 psi) at -40 to 100°C (212°F).
- Maximum pressure 206 bar (3000 psi) at 215°C (420°F).
- Graphite.
- Maximum pressure 250 bar (3625 psi) at -40 to 100°C (212°F).
- Maximum pressure 155 bar (2250 psi) at 450°C (842°F).

Materials Certificates, Testing, and Traceability

Material Certificates and Traceability

Each SmartLine manifold body is permanently marked with an alphanumeric traceability code called assembly A-number.

Furthermore, the individual valveheads are pre-assembled and get their own traceability code marked onto them before being installed into the manifold bodies. These codes link each component to manufacturing, assembly and mill test reports (MTR's).

The A-Number is stored in our ISO 9001 quality management system and corresponds to our Material Certificate Register (MCR).

An MCR is supplied with every order to the customer. This document gives a list of the corresponding material batch numbers and grades for all wetted components used to assemble that specific batch of manifolds. Along with this MCR, mill test reports (MTR's) are also supplied in a mini data book.

All SmartLine manifolds carry permanent markings of complete model code (including material of construction, certificates etc.), pressure and temperature ratings and a logic diagram.

The material of construction marking pertains to all the wetted components in the valve/manifold.

Testing and Quality Control

All components undergo 100% size testing during the manufacturing process. From there the components will be assembled into the final product which gets pressure tested to confirm correct operation. To keep to the highest possible standard, 100% of the finished products are tested.

Honeywell's standard testing procedure conforms to MSS-SP-99*. Each manifold is tested in such a way that every valve seat in the manifold, as well as every valvehead's stem packing and bonnet to body seal is checked. This test utilizes pressurized nitrogen gas at a minimum of 750 psi (MSS-SP-99 only requires 80 psi). Honeywell does not permit any leakage at all through the seat or the stem packing during testing.

The results are then recorded, and a report compiled.

Refer to the Model Selection Guide section (Table 4) for the available certificate options.

* For code applications where a hydrostatic 1.5X over-pressure shell test needs to be performed, Honeywell uses the MSS-SP-105 testing procedure. This testing is done on special request.

Specifications

Manufacturing Standards and Compliance

SmartLine Manifolds are designed, manufactured and tested to the highest possible standards and can have the following standards and regulations applied as required:

ASME BPVC VIII Div 1	ASME Boiler Pressure Vessel Code Section 8 Division 1
ASME B31.1	Power Piping
ASME B31.3	Process Piping
ASME B16.34	Valves Flanged, Threaded
ISO 9001:2008	Certified Quality System
MSS-SP-99	Instrument Valves
MSS-SP-105	Instrument valves for code applications
MSS-SP-25	Standard marking system for valves, fittings, flanges and unions
MSS-SP-61	Hydrostatic testing of steel valves
NACE	National Association of Corrosion Engineers
NACE MR0175 / ISO 15156	Materials for use in H ₂ S-containing environments in oil and gas production.
NACE MR0103	Materials Resistant to Sulfide Stress Cracking in Corrosive Petroleum Refining Environments.
NORSOK M650	Qualification of manufacturers of special materials.
EN 10204 3.1 or 3.2	Mill Test Reports
ASME B1.20.1	General Pipe Threads or high tolerance thread.
ASTM A182	Forged or Rolled Alloy - Steel Pipe Flanges, Forged Fittings, and Valves and Parts for High Temperature Service.
ASTM A276	Standard Specification for Stainless Steel Bars and Shapes.
ASTM A479	Stainless Steel Bars and Shapes for Use in Boilers and other Pressure Vessels.
SANS 347	Categorization and conformity assessment criteria for all pressure equipment.
P.E.R	Pressure Equipment Regulations (South Africa)
P.E.D	Pressure Equipment Directive (Europe)
IEC 61518 Type B	Mating Dimensions between DP (Type) Measuring Instrument and Flanged-on Shut-Off devices (Manifolds).

Pressure Equipment Directive (P.E.D 97/23/EC) (Europe)

Due to internal bore size and internal volumes up to and including 1"/25mm, products offered in this catalogue comply with S.E.P (Sound Engineering Practice) article 3, paragraph 3 of the Pressure Equipment Directive P.E.D 97/23/EC and therefore CE marking is not applicable.

Vent / Bleed Port Plugs

Preference X

Following vent / bleed / test port plug options are available in matching material of construction of manifolds.

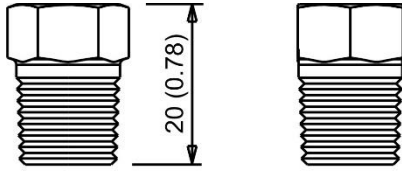

Standard Plug

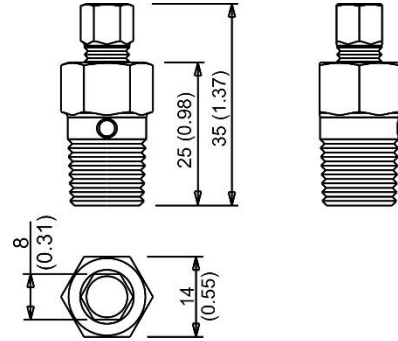

Bleed Plug

Bolts

Bolts for Traditional Style Manifolds (Wide / Compact Bodies)

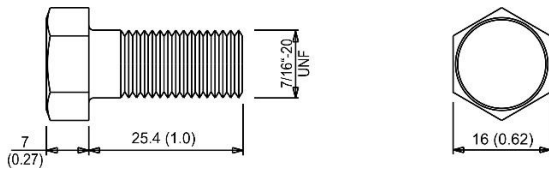

Carbon Steel Bolt

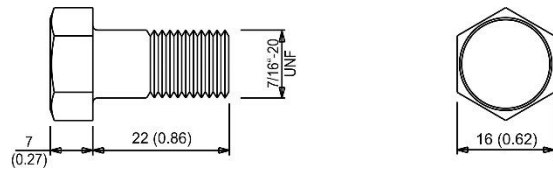

Stainless Steel / Exotic Material Bolt

Bolts for Wafer Style Manifolds

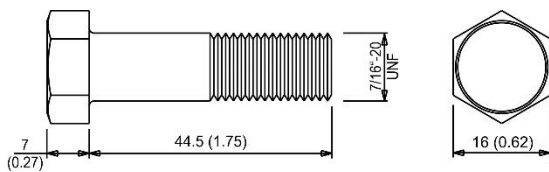

Carbon Steel Bolt

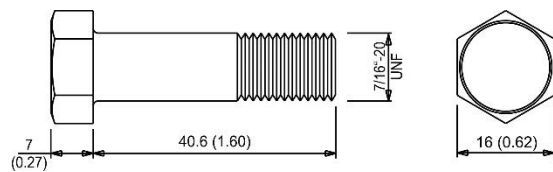

Stainless Steel / Exotic Material Bolt

Vent / Bleed Port Plugs

Preference Z

Following vent / bleed / test port plug options are available in matching material of construction of manifolds.

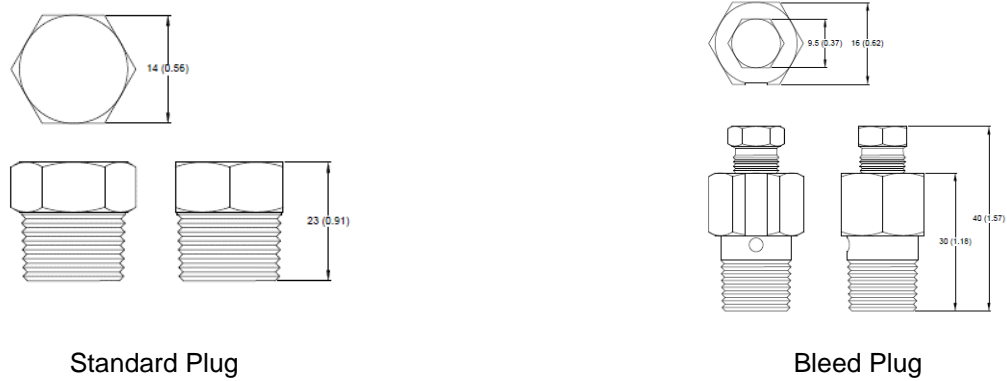

Standard Plug

Bleed Plug

Bolts

Bolts for Traditional Style Manifolds (Wide / Compact Bodies)

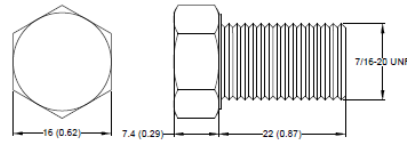

Carbon Steel / Stainless Steel / Exotic Material Bolt

Bolts for Wafer Style Manifolds

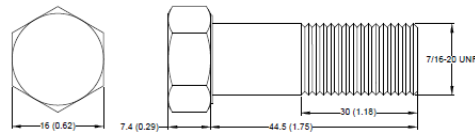

Carbon Steel / Stainless Steel / Exotic Material Bolt

Manifold Section - Preference X

All designs are available with anti-tamper taps. An anti-tamper key (see Accessories list) shall be ordered separately whenever manifolds are ordered with anti-tamper taps.

Single Block and Bleed Manifolds

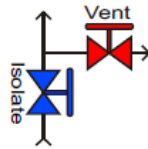

Process connection:
 1/2" NPT Female
Transmitter Connection:
 1/2" NPT Male
Vent/ Bleed / Drain Location:
 Side
Approximate Weight:
 0.50 kg (1.10 lbs.)

MSG Option:
 STMSB - A _ _

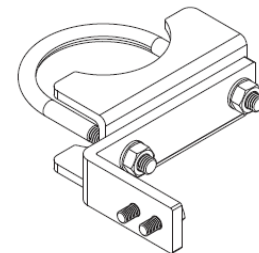
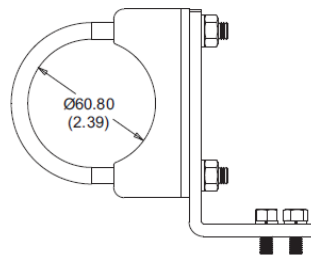
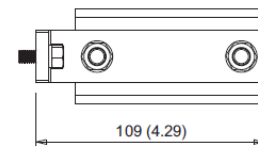
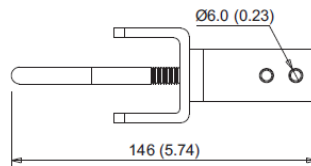
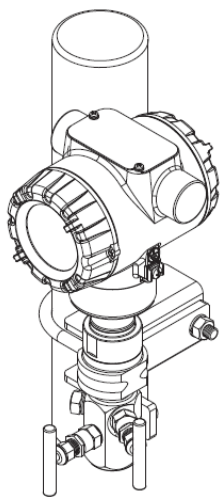
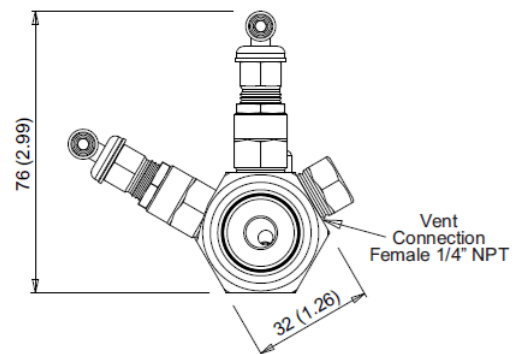
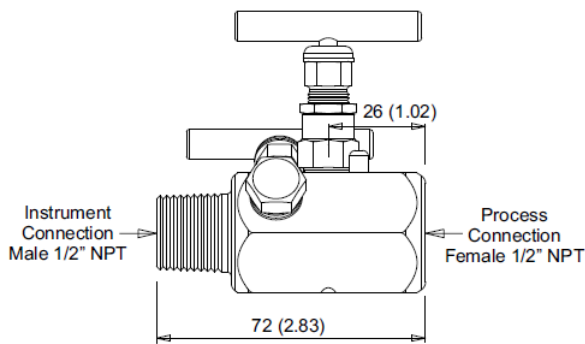

Approximate Weight of Mounting Bracket: 0.60 kg (1.32 lbs.)
 Refer to Table 3 in [Model Selection Guide](#) for Mounting Bracket Options.

Single Block and Bleed Manifolds

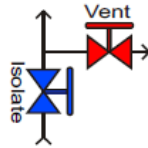
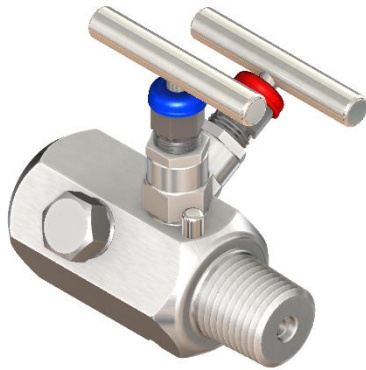

Process connection:
 1/2" NPT Male
Transmitter Connection:
 1/2" NPT Female
Vent/ Bleed / Drain Location:
 Side
Approximate Weight:
 0.50 kg (1.10 lbs.)

MSG Option:
 STMSB - B_ _

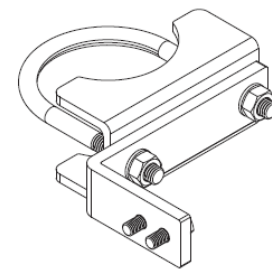
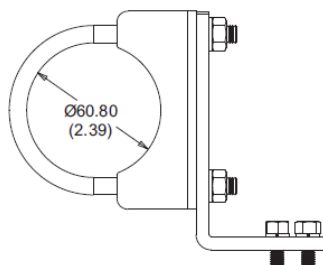
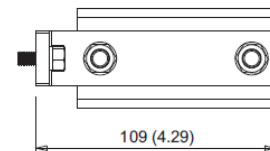
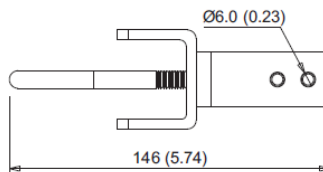
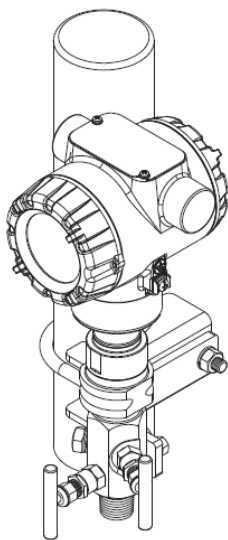
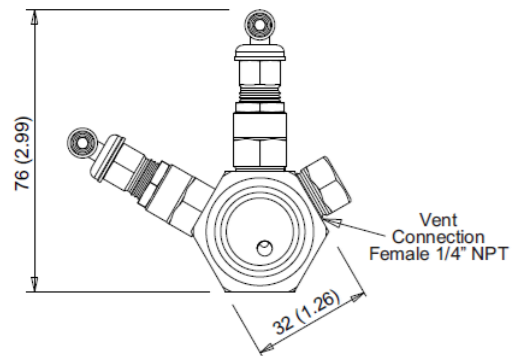
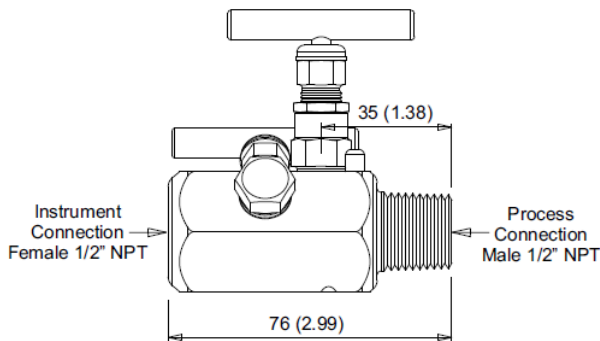

Approximate Weight of Mounting Bracket: 0.60 kg (1.32 lbs.)
 Refer to Table 3 in [Model Selection Guide](#) for Mounting Bracket Options.

Single Block and Bleed Manifolds

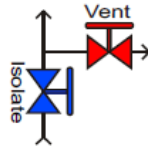

Process connection:
 1/2" NPT Female
Transmitter Connection:
 1/2" NPT Female
Vent/ Bleed / Drain Location:
 Side
Approximate Weight:
 0.50 kg (1.10 lbs.)

MSG Option:
 STMSB - C _ _

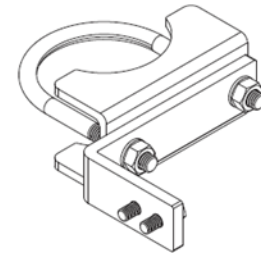
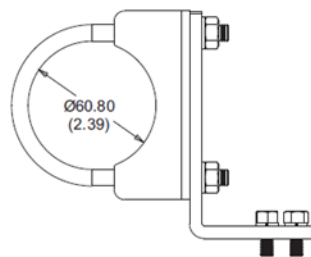
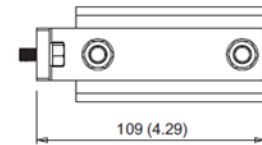
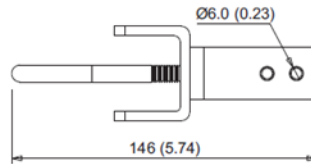
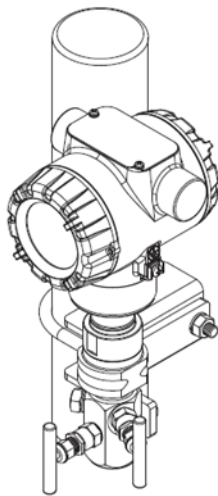
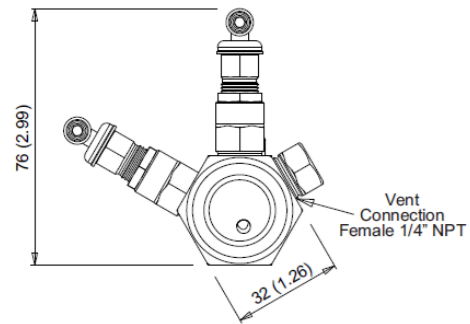
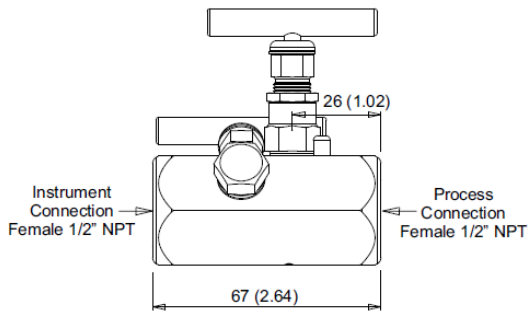

Approximate Weight of Mounting Bracket: 0.60 kg (1.32 lbs.)
 Refer to Table 3 in [Model Selection Guide](#) for Mounting Bracket Options.

Double Block and Bleed Manifolds

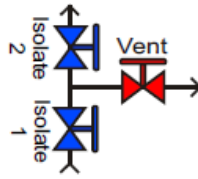
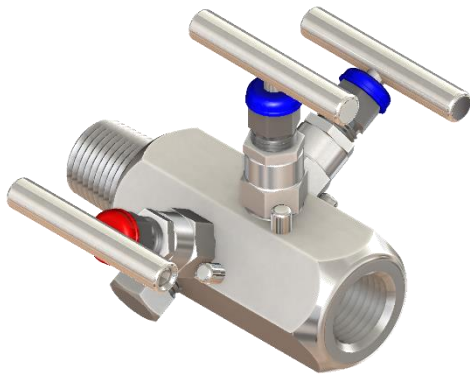

Process connection:

1/2" NPT Female

Transmitter Connection:

1/2" NPT Male

Vent/ Bleed / Drain Location:

Side

Approximate Weight:

0.59 kg (1.30 lbs.)

MSG Option:

STMDB - A_ _

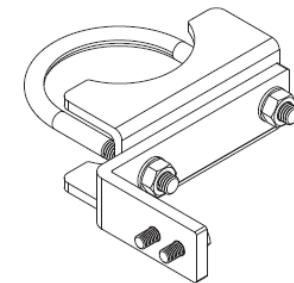
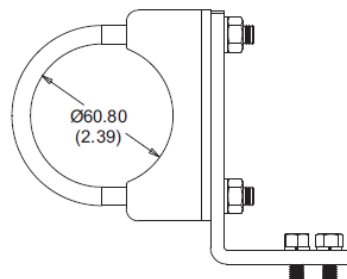
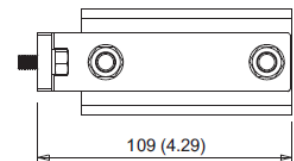
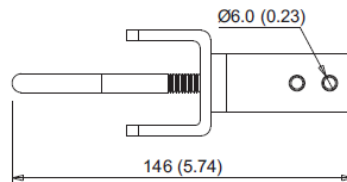
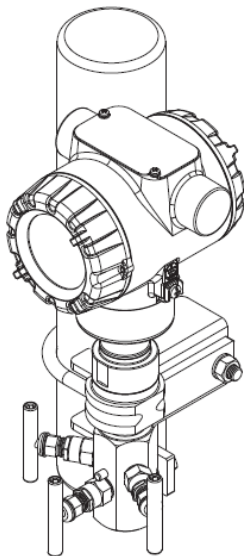
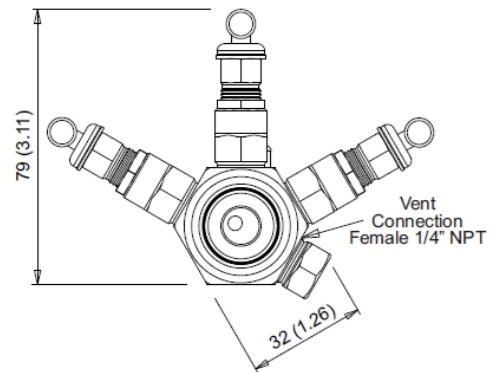
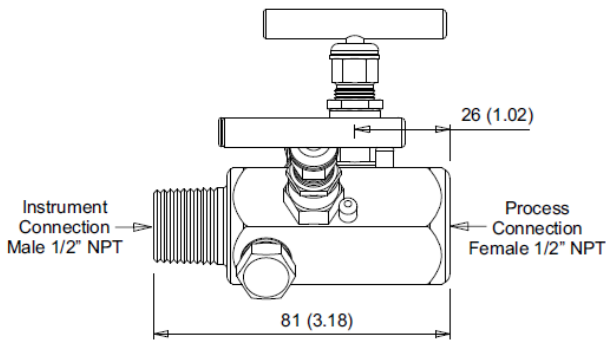

Approximate Weight of Mounting Bracket: 0.60 kg (1.32 lbs.)

Refer to Table 3 in [Model Selection Guide](#) for Mounting Bracket Options.

Double Block and Bleed Manifolds

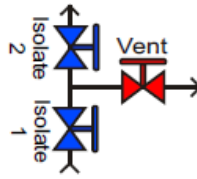
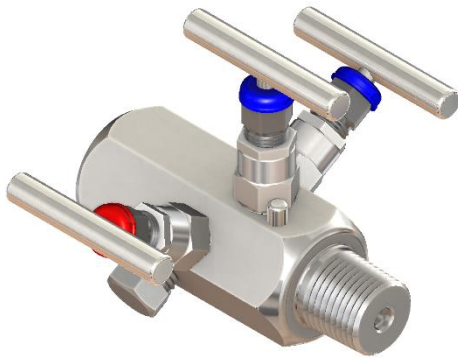

Process connection:

1/2" NPT Male

Transmitter Connection:

1/2" NPT Female

Vent/ Bleed / Drain Location:

Side

Approximate Weight:

0.59 kg (1.30 lbs.)

MSG Option:

STMDB - B_ _

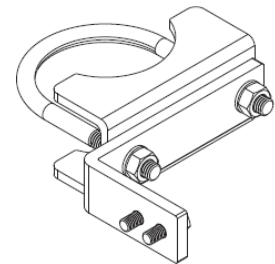
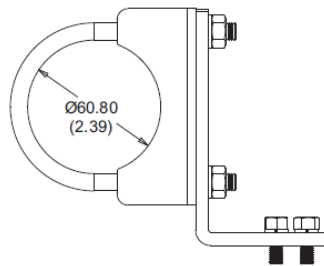
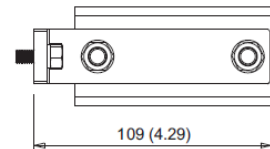
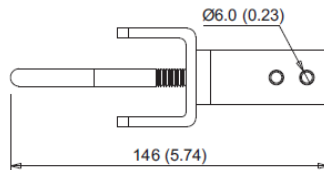
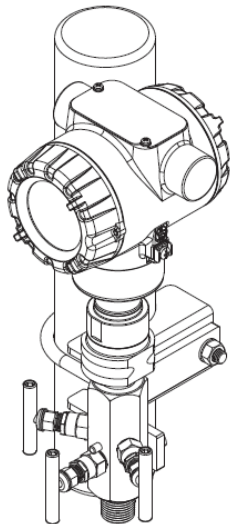
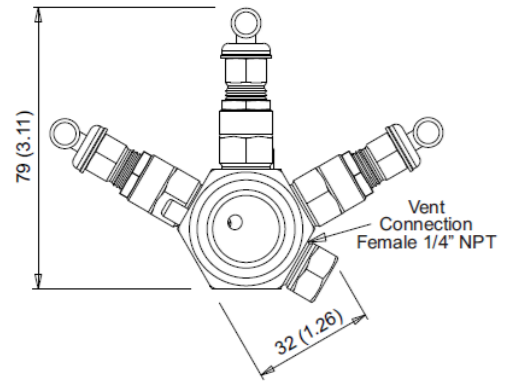
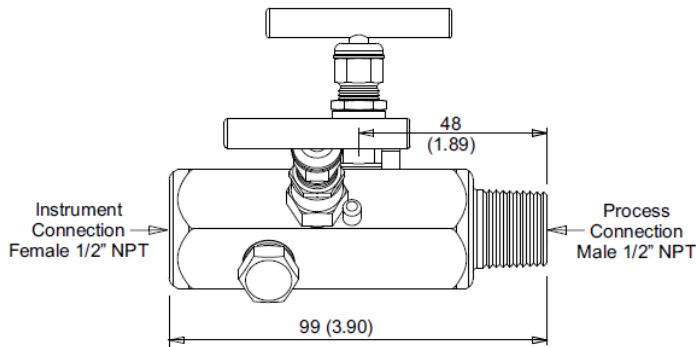

Approximate Weight of Mounting Bracket: 0.60 kg (1.32 lbs.)

Refer to Table 3 in [Model Selection Guide](#) for Mounting Bracket Options.

Double Block and Bleed Manifolds

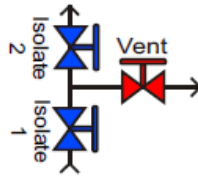
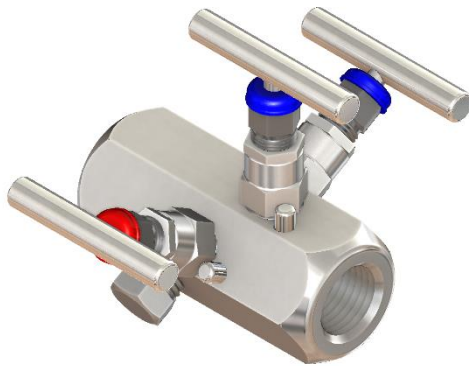

Process connection:

1/2" NPT Female

Transmitter Connection:

1/2" NPT Female

Vent/ Bleed / Drain Location:

Side

Approximate Weight:

0.59 kg (1.30 lbs.)

MSG Option:

STMDB - C_ _

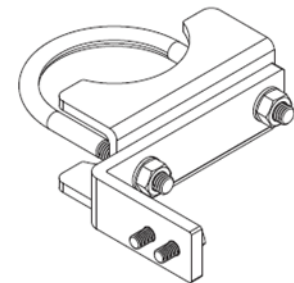
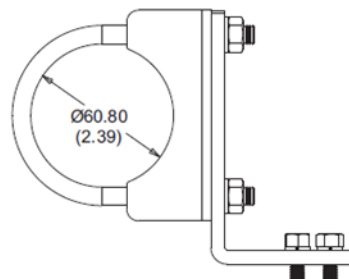
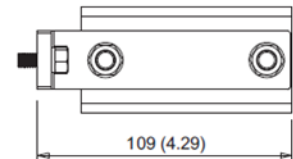
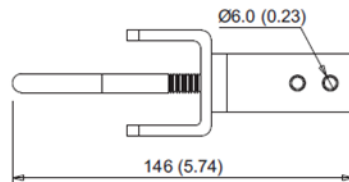
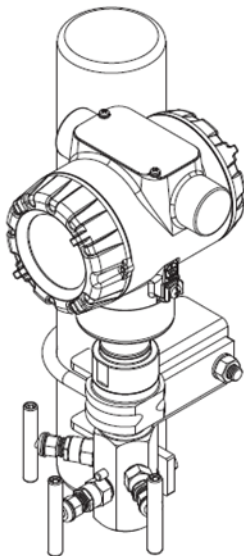
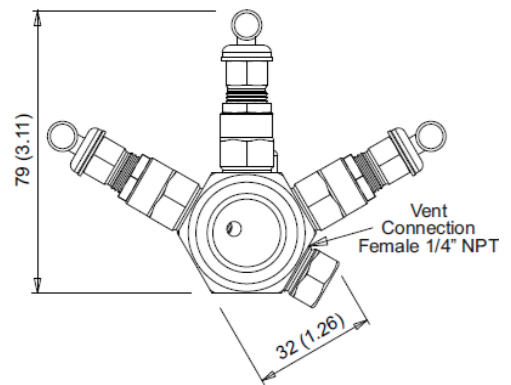
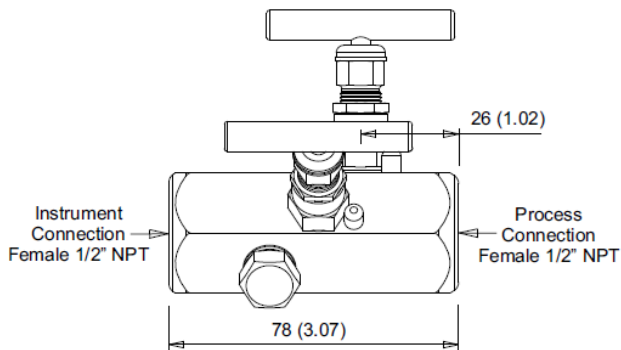

Approximate Weight of Mounting Bracket: 0.60 kg (1.32 lbs.)

Refer to Table 3 in [Model Selection Guide](#) for Mounting Bracket Options..

2 Valve Wide Liquid Level Manifold

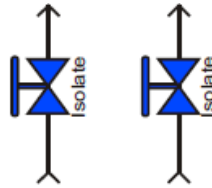
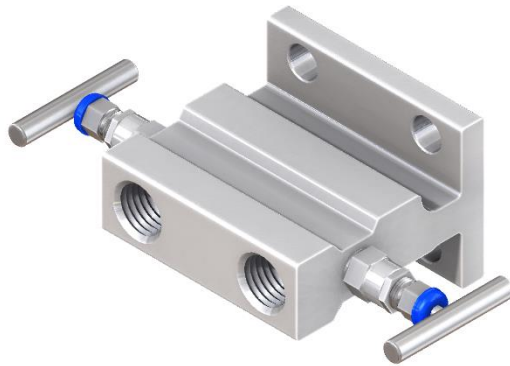

Process connection:

1/2" NPT Female

Transmitter Connection:

Flanged

Vent/ Bleed / Drain Location:

N/A

Approximate Weight:

1.45 kg (3.19 lbs.)

MSG Option:

STMD2 - D_ _

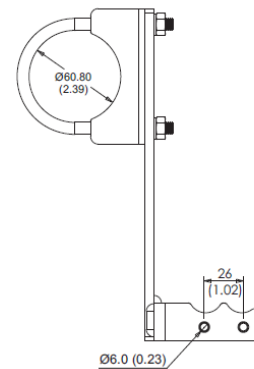
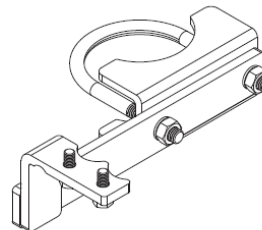
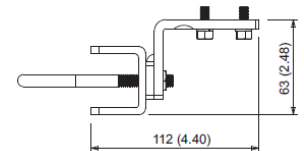
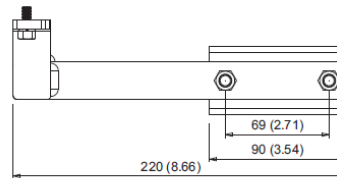
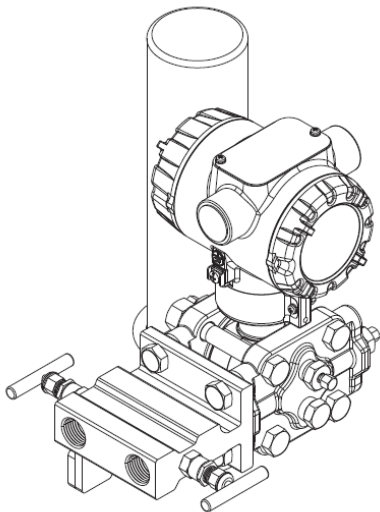
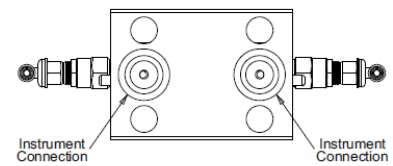
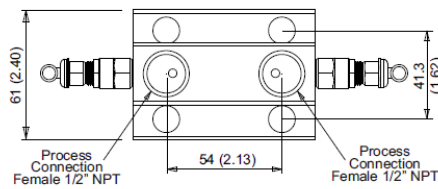
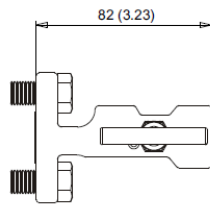

Approximate Weight of Mounting Bracket: 0.70 kg (1.54 lbs.)

Refer to Table 3 in [Model Selection Guide](#) for Mounting Bracket Options.

2 Valve Compact Body Manifold

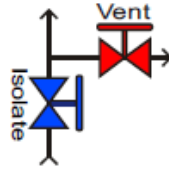
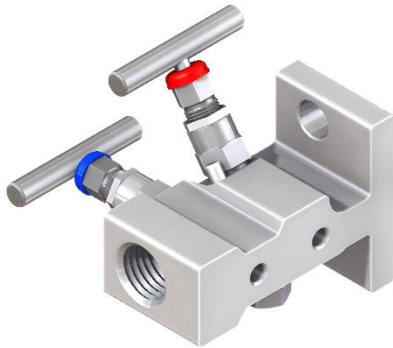

Process connection:

1/2" NPT Female

Transmitter Connection:

Flanged

Vent/ Bleed / Drain Location:

Bottom

Approximate Weight:

0.80 kg (1.76 lbs.)

MSG Option:

STMD2 - E _ _

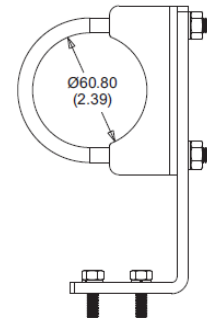
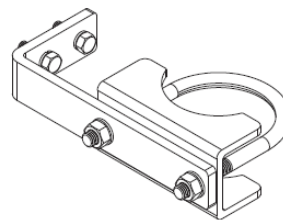
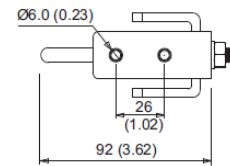
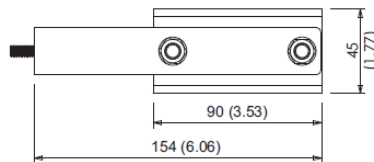
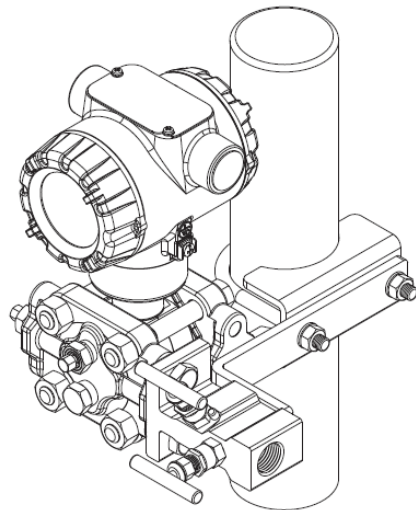
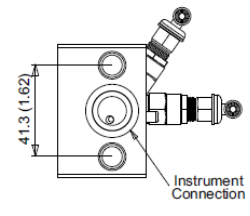
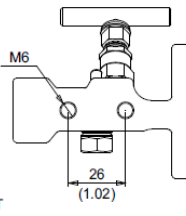
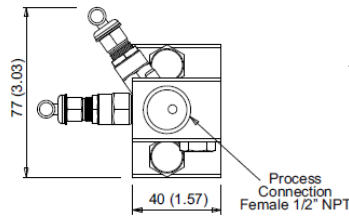
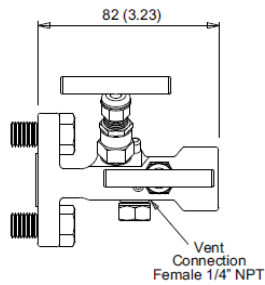

Approximate Weight of Mounting Bracket: 0.60 kg (1.32 lbs.)

Refer to Table 3 in [Model Selection Guide](#) for Mounting Bracket Options.

2 Valve Wide Body Manifold

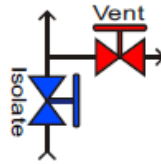
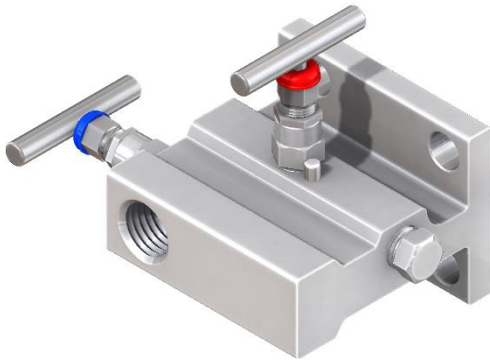

Process connection:
 1/2" NPT Female
Transmitter Connection:
 Flanged
Vent/ Bleed / Drain Location:
 Side
Approximate Weight:
 1.4 kg (3.08 lbs.)

MSG Option:
 STMD2 - F _ _

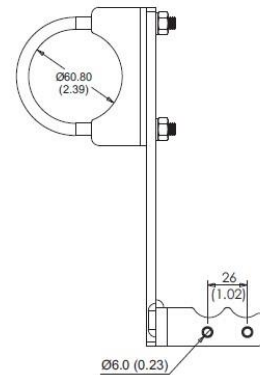
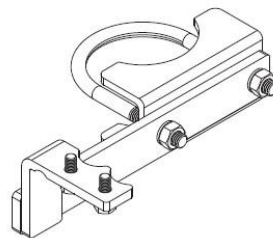
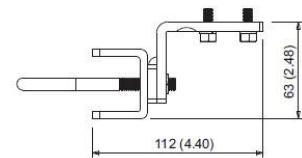
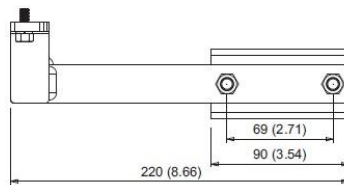
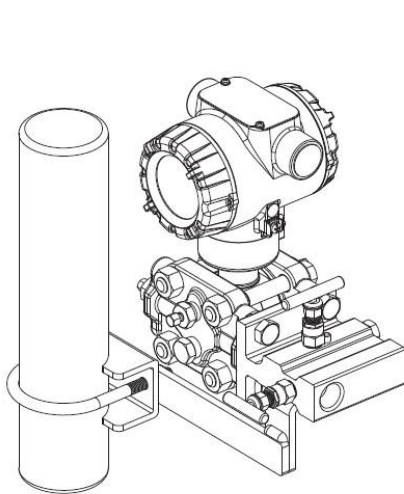
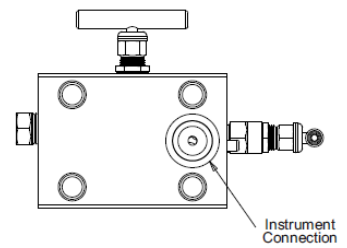
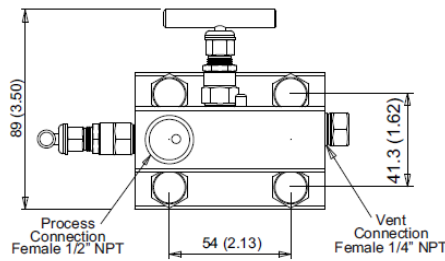
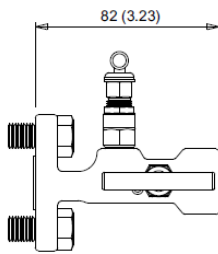

Approximate Weight of Mounting Bracket: 0.70 kg (1.54 lbs.)
 Refer to Table 3 in [Model Selection Guide](#) for Mounting Bracket Options.

2 Valve Wafer Style Manifold

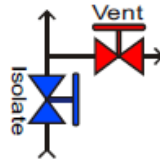
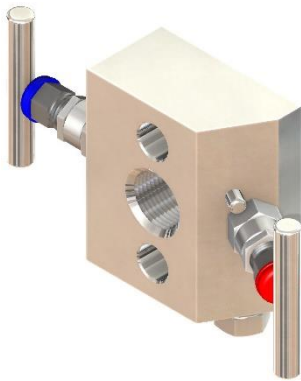

Process connection:
 1/2" NPT Female
Transmitter Connection:
 Flanged
Vent/ Bleed / Drain Location:
 Bottom
Approximate Weight:
 1.40 kg (3.08 lbs.)

MSG Option:
 STMD2 - G _ _

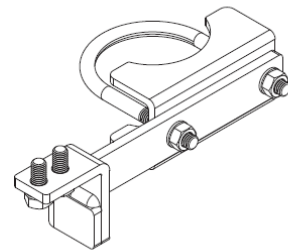
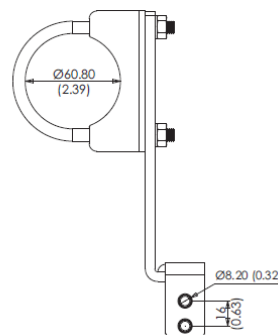
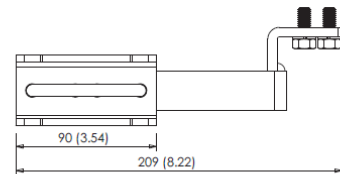
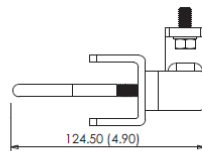
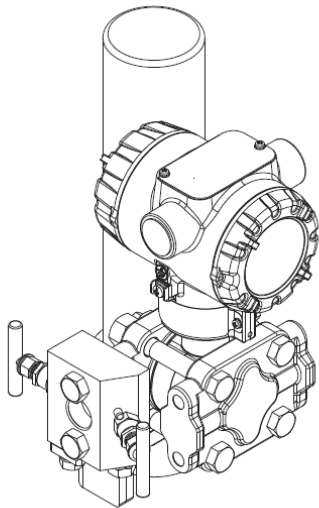
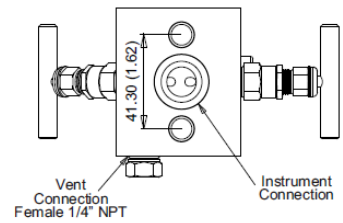
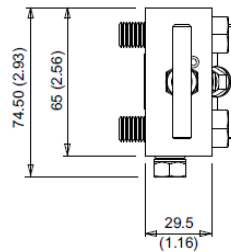
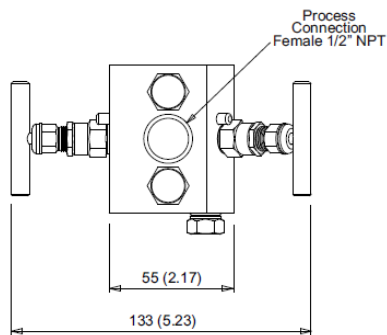

Approximate Weight of Mounting Bracket: 0.70 kg (1.54 lbs.)
 Refer to Table 3 in [Model Selection Guide](#) for Mounting Bracket Options.

2 Valve Compact Body Manifold (Flange X Flange)

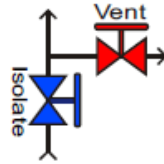
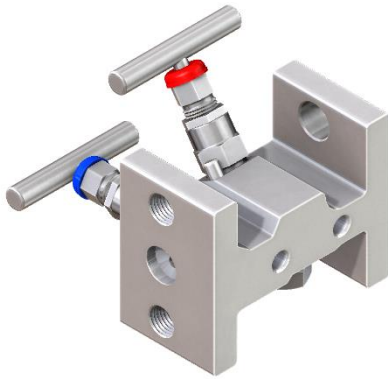

Process connection:
Flanged
Transmitter Connection:
Flanged
Vent/ Bleed / Drain Location:
Side
Approximate Weight:
0.85 kg (1.87 lbs.)

MSG Option:
STMD2 - H _ _

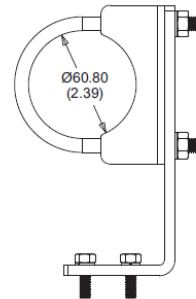
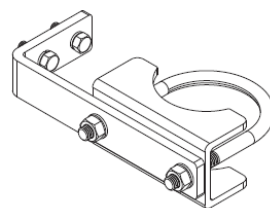
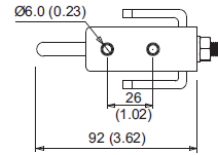
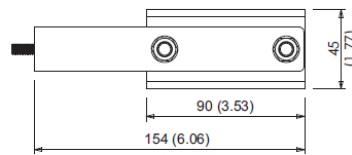
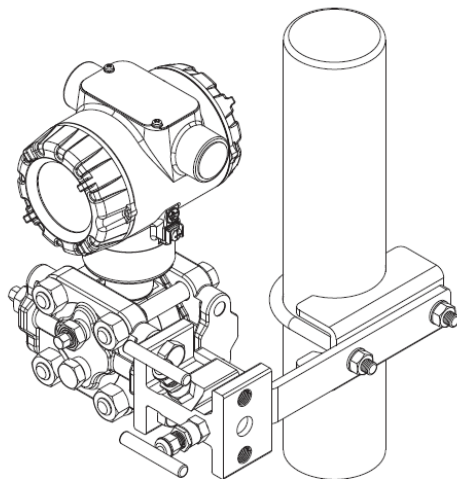
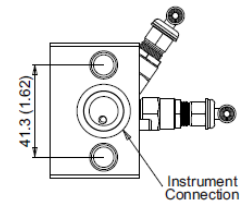
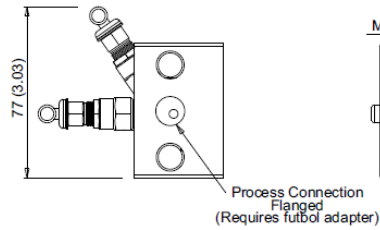
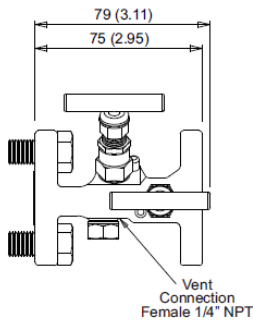

Approximate Weight of Mounting Bracket: 0.60 kg (1.32 lbs.)
Refer to Table 3 in [Model Selection Guide](#) for Mounting Bracket Options.

2 Valve Wide Body Manifold (Flange X Flange)

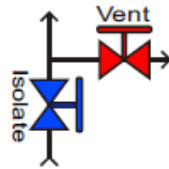
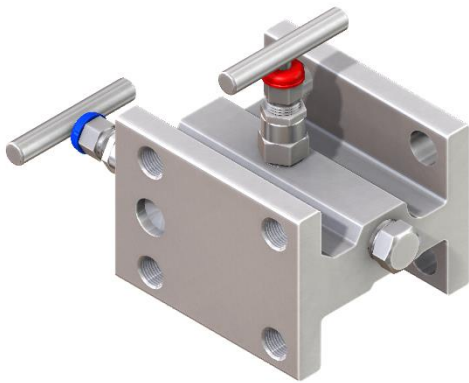

Process connection:
Flanged
Transmitter Connection:
Flanged
Vent/ Bleed / Drain Location:
Side
Approximate Weight:
1.5 kg (3.30 lbs.)

MSG Option:
STMD2 - J _ _

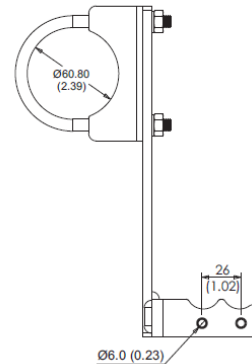
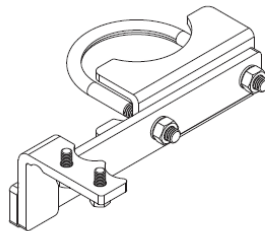
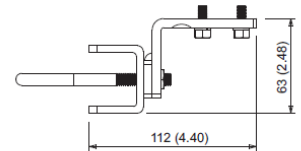
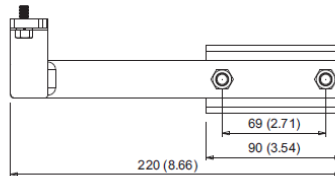
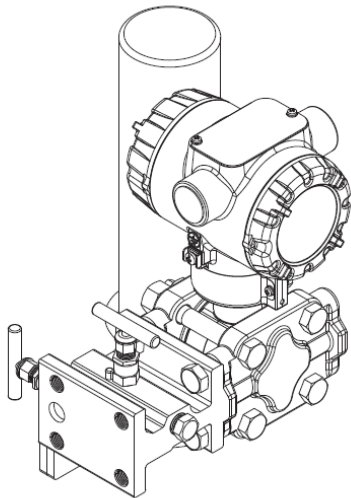
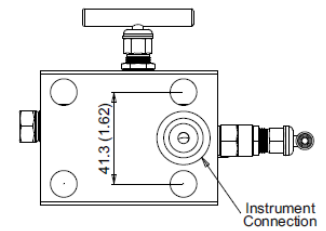
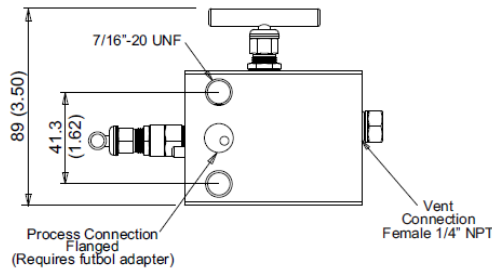
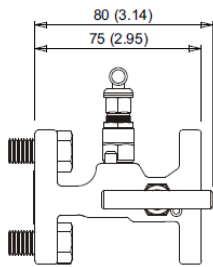

Approximate Weight of Mounting Bracket: 0.70 kg (1.54 lbs.)
Refer to Table 3 in [Model Selection Guide](#) for Mounting Bracket Options.

3 Valve Wide Body Manifold

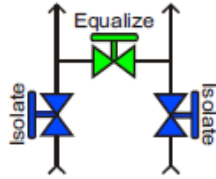
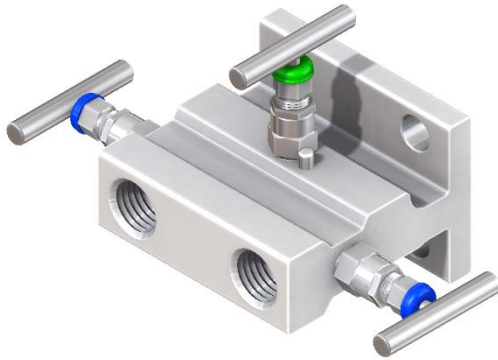

Process connection:
 ½" NPT Female
Transmitter Connection:
 Flanged
Vent/ Bleed / Drain Location:
 N/A
Approximate Weight:
 1.65 kg (3.63 lbs.)

MSG Option:
 STMD3 - K _ _

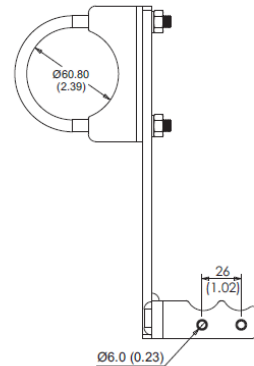
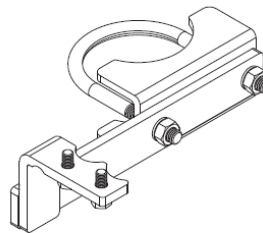
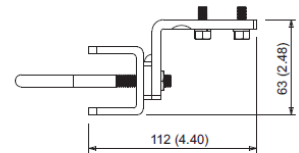
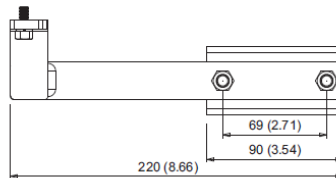
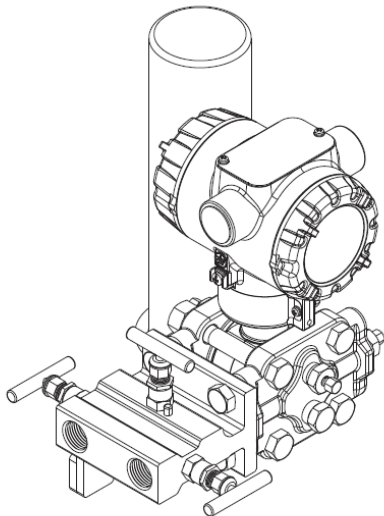
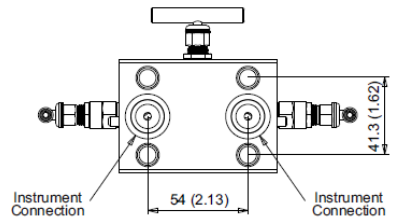
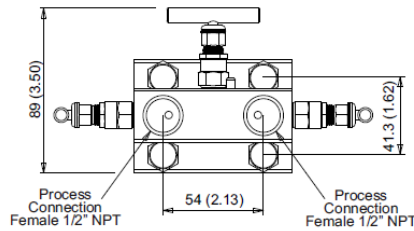
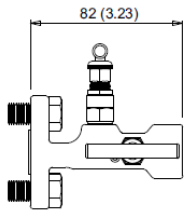

Approximate Weight of Mounting Bracket: 0.70 kg (1.54 lbs.)
 Refer to Table 3 in [Model Selection Guide](#) for Mounting Bracket Options.

3 Valve Wide Body Manifold with Bleed Ports

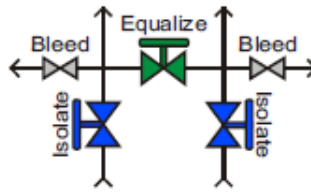
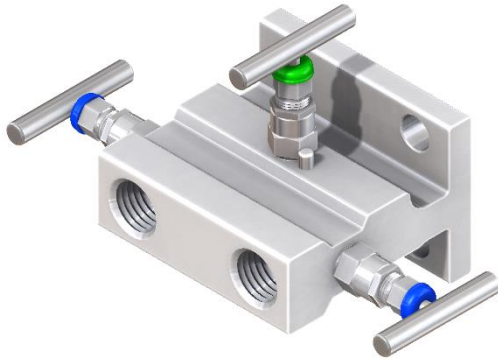

Process connection:

1/2" NPT Female

Transmitter Connection:

Flanged

Vent/ Bleed / Drain Location:

Bottom

Approximate Weight:

1.65 kg (3.63 lbs.)

MSG Option:

STMD3 - L _ _

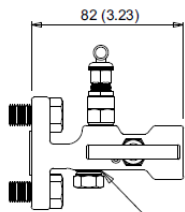

Vent Connections Female 1/4" NPT

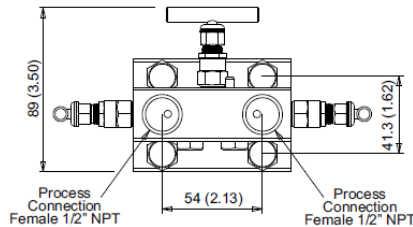

Process Connection Female 1/2" NPT

Process Connection Female 1/2" NPT

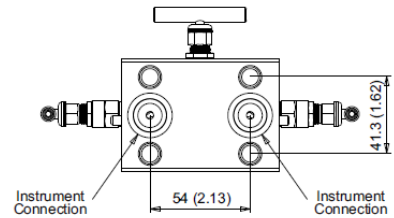

Instrument Connection

Instrument Connection

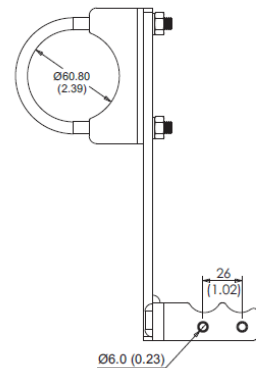
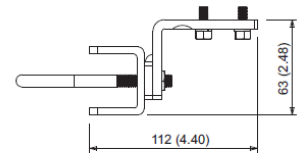
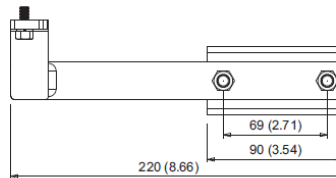
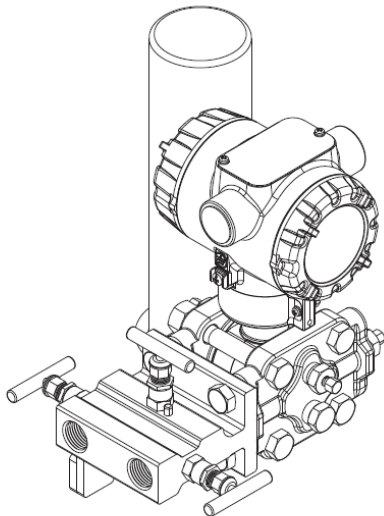

Approximate Weight of Mounting Bracket: 0.70 kg (1.54 lbs.)

Refer to Table 3 in [Model Selection Guide](#) for Mounting Bracket Options.

3 Valve Wafer Style Manifold

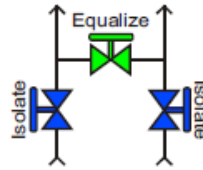
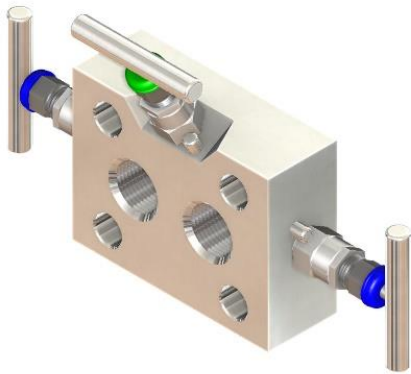

Process connection:
 1/2" NPT Female
Transmitter Connection:
 Flanged
Vent/ Bleed / Drain Location:
 N/A
Approximate Weight:
 1.52 kg (3.34 lbs.)

MSG Option:
 STMD3 - M _ _

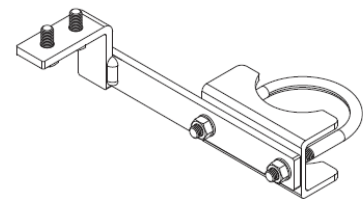
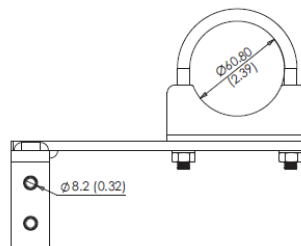
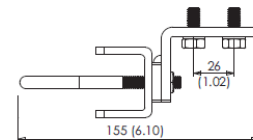
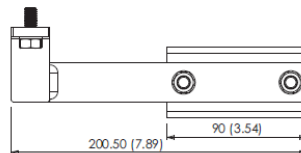
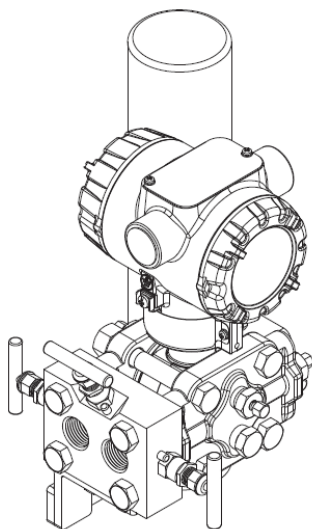
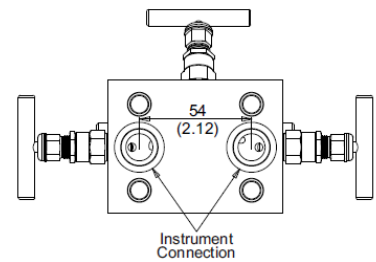
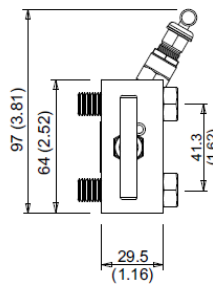
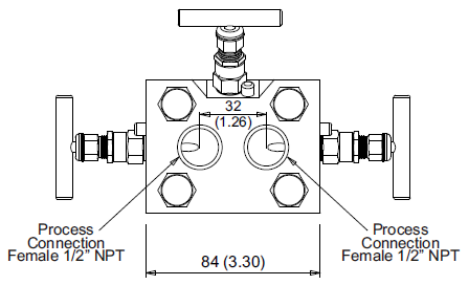

Approximate Weight of Mounting Bracket: 0.70 kg (1.54 lbs.)
 Refer to Table 3 in [Model Selection Guide](#) for Mounting Bracket Options.

3 Valve Wafer Style Manifold with Bleed Ports

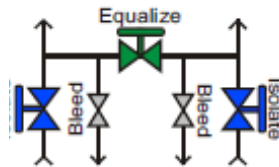
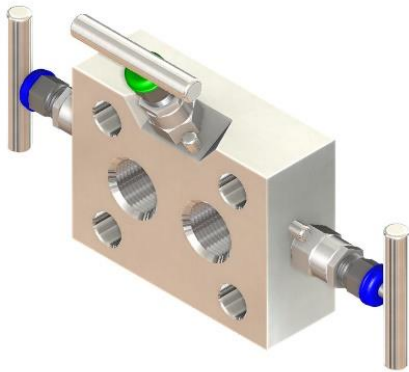

Process connection:
 1/2" NPT Female
Transmitter Connection:
 Flanged
Vent/ Bleed / Drain Location:
 Bottom
Approximate Weight:
 1.52 kg (3.34 lbs.)

MSG Option:
 STMD3 - N _ _

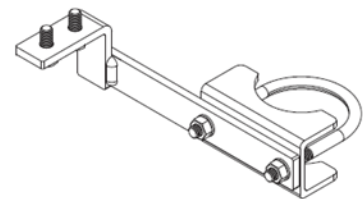
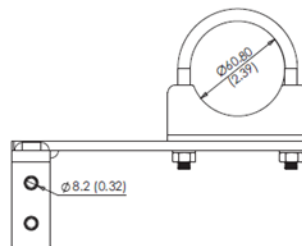
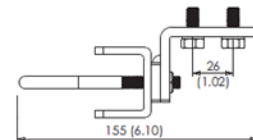
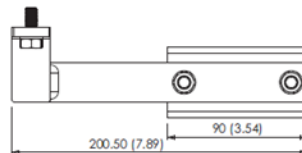
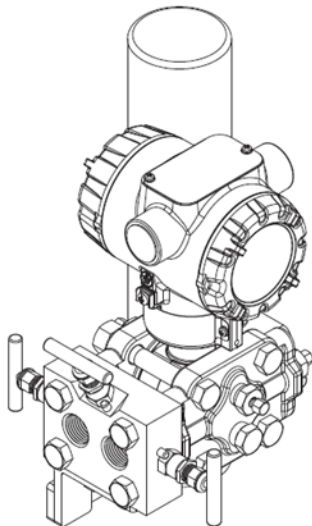
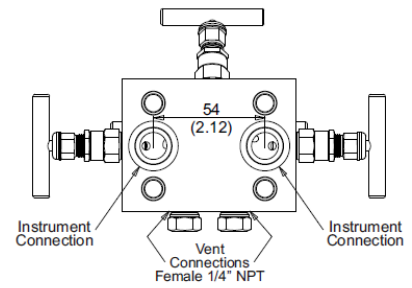
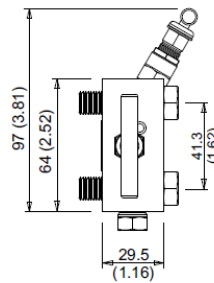
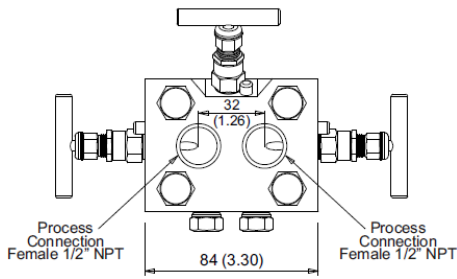

Approximate Weight of Mounting Bracket: 0.70 kg (1.54 lbs.)
 Refer to Table 3 in [Model Selection Guide](#) for Mounting Bracket Options.

3 Valve Wide Body Manifold (Flange X Flange)

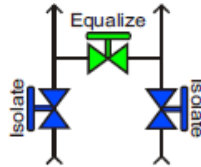
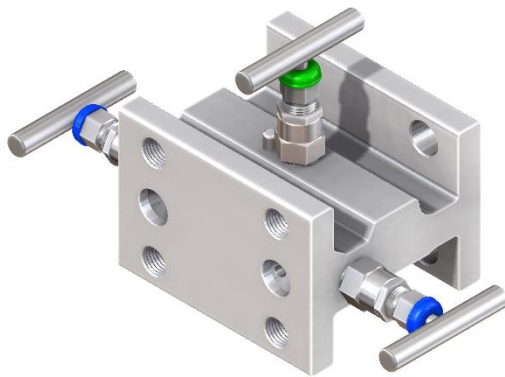

Process connection:
Flanged
Transmitter Connection:
Flanged
Vent/ Bleed / Drain Location:
N/A
Approximate Weight:
1.75 kg (3.85 lbs.)

MSG Option:
STMD3 - O _ _

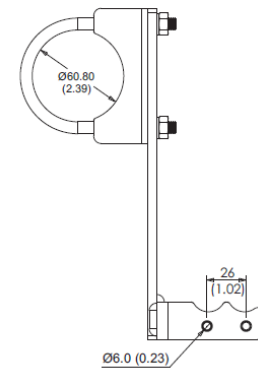
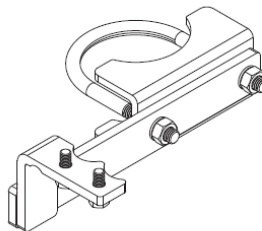
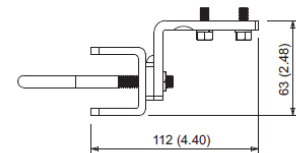
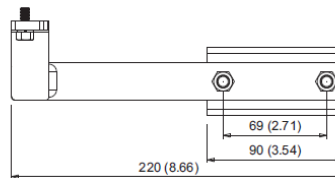
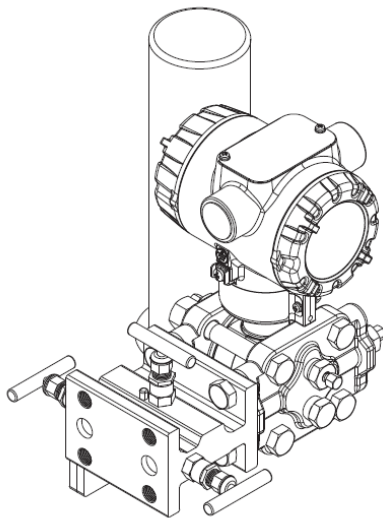
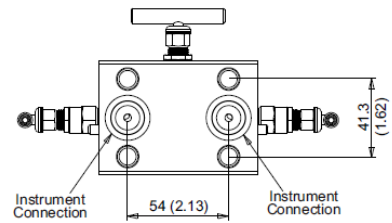
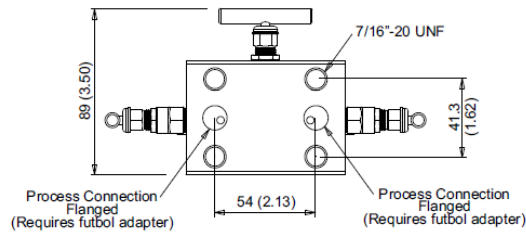
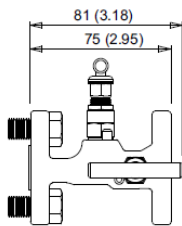

Approximate Weight of Mounting Bracket: 0.70 kg (1.54 lbs.)

Refer to Table 3 in [Model Selection Guide](#) for Mounting Bracket Options.

3 Valve Wide Body Manifold (Flange X Flange) with Bleed Ports

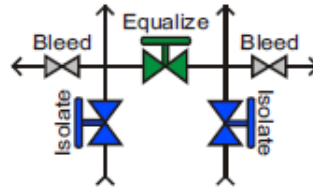
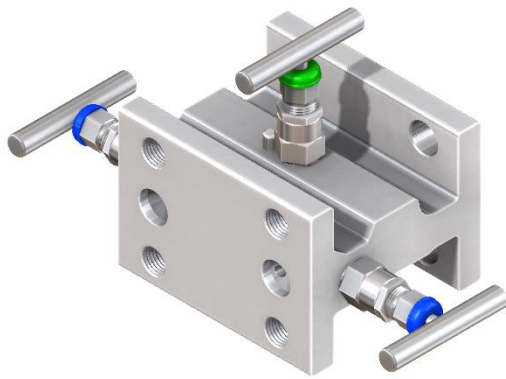

Process connection:
Flanged
Transmitter Connection:
Flanged
Vent/ Bleed / Drain Location:
Bottom
Approximate Weight:
1.75 kg (3.85 lbs.)

MSG Option:
STMD3 - P _ _

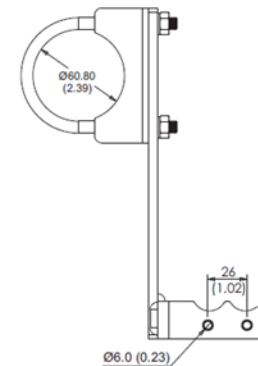
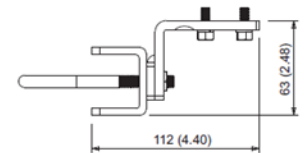
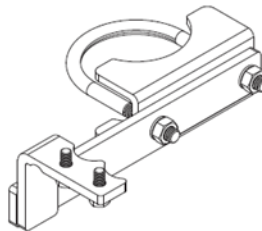
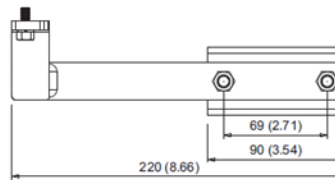
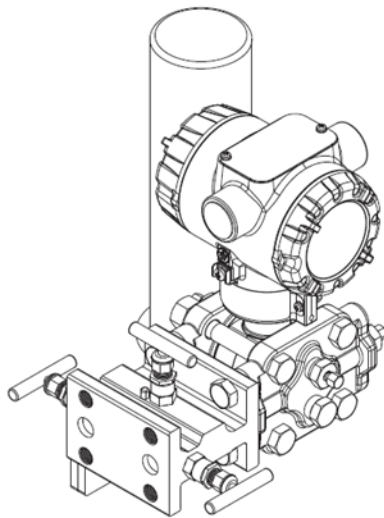
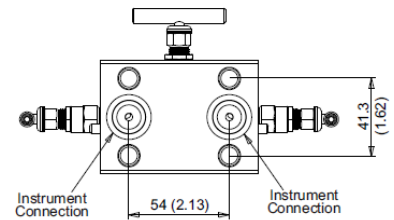
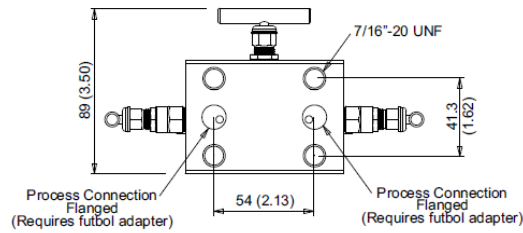
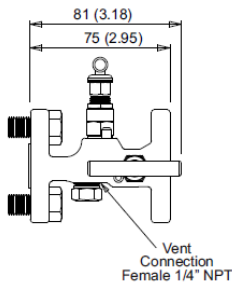

Approximate Weight of Mounting Bracket: 0.70 kg (1.54 lbs.)
Refer to Table 3 in [Model Selection Guide](#) for Mounting Bracket Options.

5 Valve Wide Body Manifold with Bleed Port at Bottom

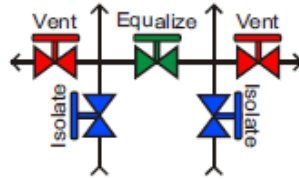
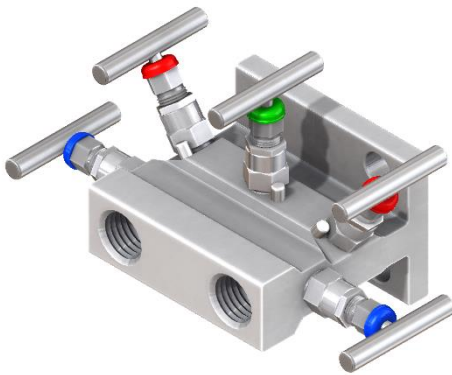

Process connection:
 1/2" NPT Female
Transmitter Connection:
 Flanged
Vent/ Bleed / Drain Location:
 Bottom
Approximate Weight:
 1.70 kg (3.74 lbs.)
MSG Option:
 STMD5 - Q _ _

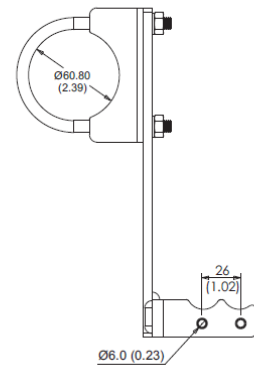
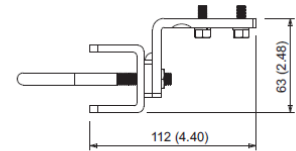
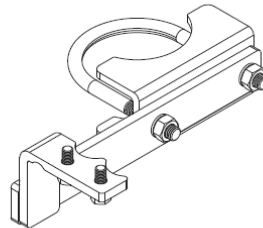
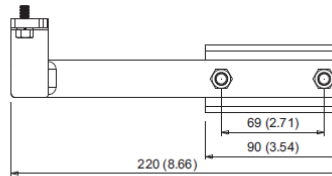
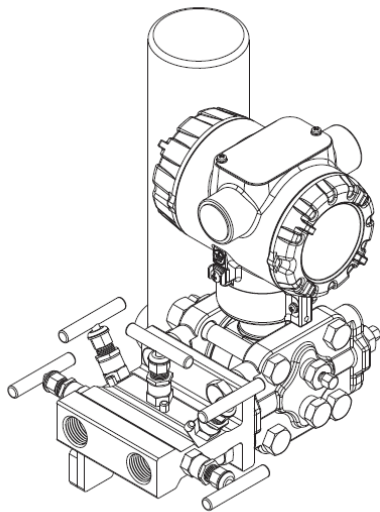
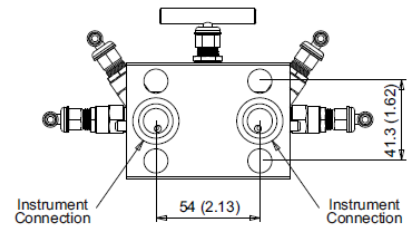
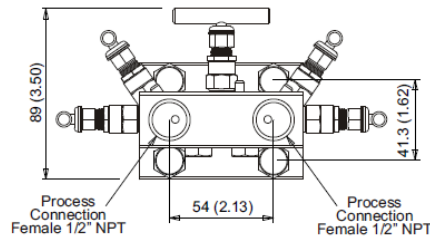
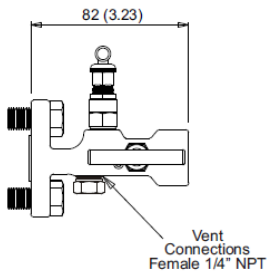

Approximate Weight of Mounting Bracket: 0.70 kg (1.54 lbs.)
 Refer to Table 3 in [Model Selection Guide](#) for Mounting Bracket Options.

5 Valve Wide Body Manifold with Bleed Port at Front

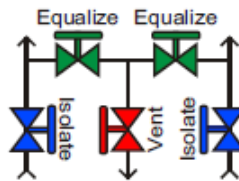
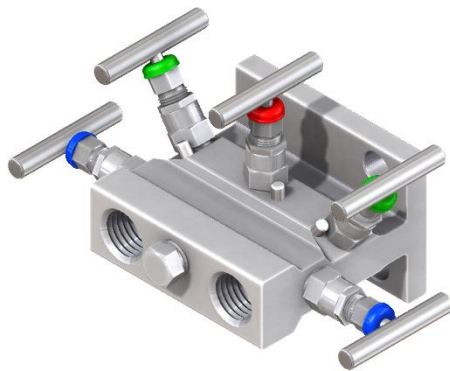

Process connection:
 1/2" NPT Female
Transmitter Connection:
 Flanged
Vent/ Bleed / Drain Location:
 Front
Approximate Weight:
 1.70 kg (3.74 lbs.)

MSG Option:
 STMD5 - R _ _

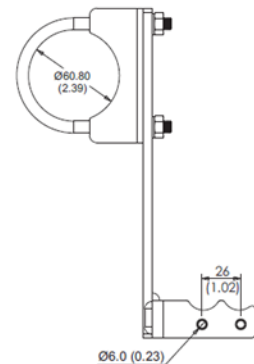
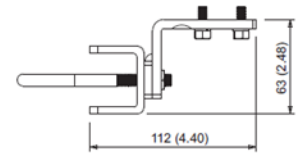
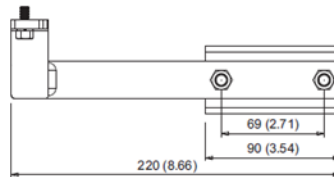
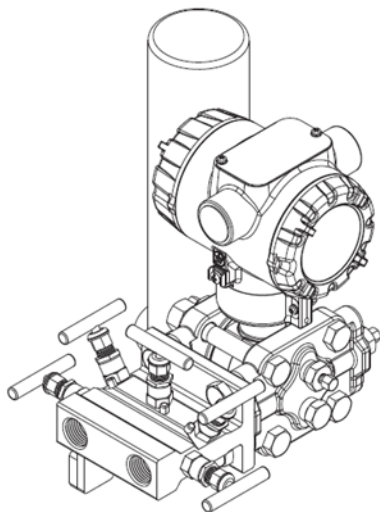
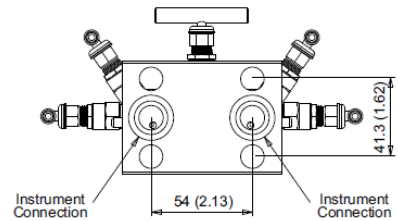
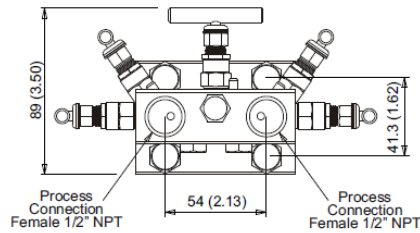
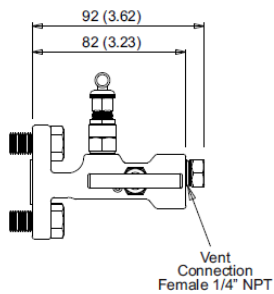

Approximate Weight of Mounting Bracket: 0.70 kg (1.54 lbs.)
 Refer to Table 3 in [Model Selection Guide](#) for Mounting Bracket Options.

5 Valve Wafer Style Manifold

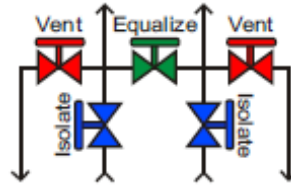
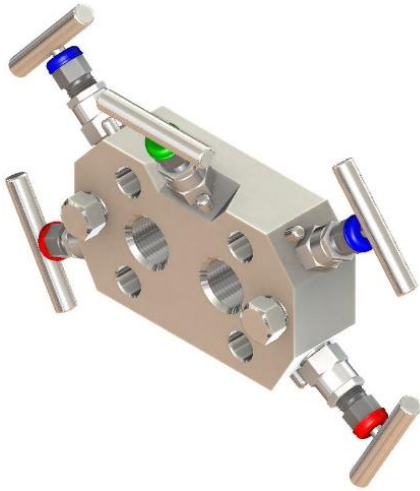

Process connection:

1/2" NPT Female

Transmitter Connection:

Flanged

Vent/ Bleed / Drain Location:

Front

Approximate Weight:

1.63 kg (3.59 lbs.)

MSG Option:

STMD5 - S _ _

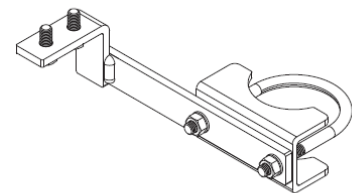
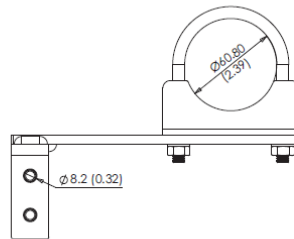
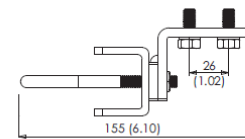
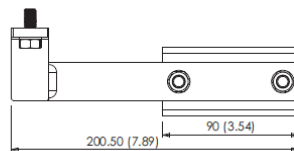
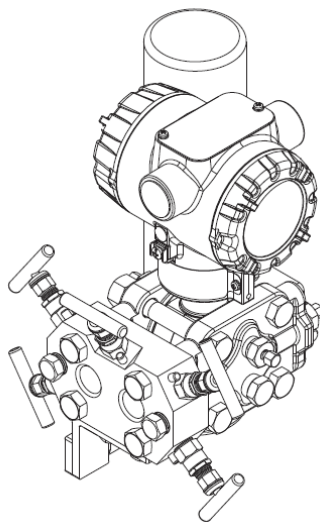
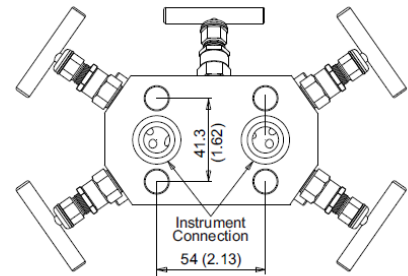
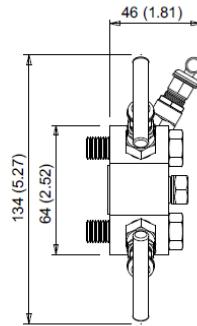
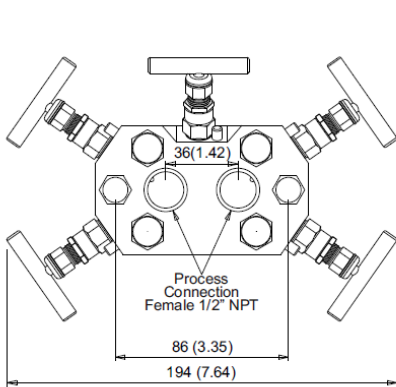

Approximate Weight of Mounting Bracket: 0.70 kg (1.54 lbs.)

Refer to Table 3 in [Model Selection Guide](#) for Mounting Bracket Options.

5 Valve Wide Body Manifold (Flange X Flange) with Bleed Port at Bottom

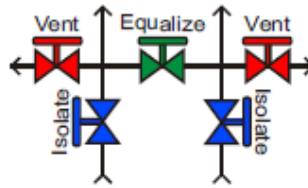
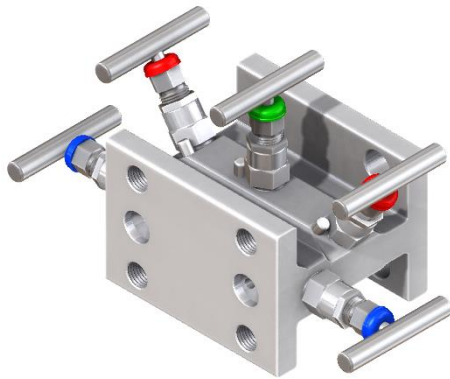

Process connection:

Flanged

Transmitter Connection:

Flanged

Vent/ Bleed / Drain Location:

Bottom

Approximate Weight:

1.85 kg (4.07 lbs.)

MSG Option:

STMD5 - T __

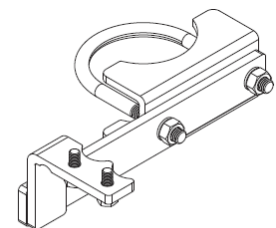
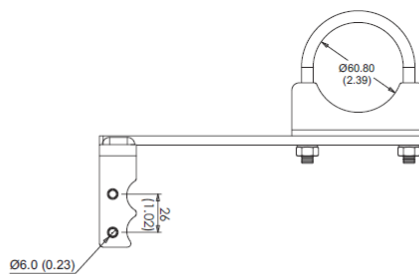
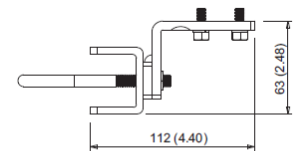
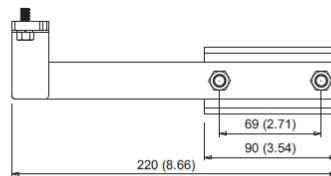
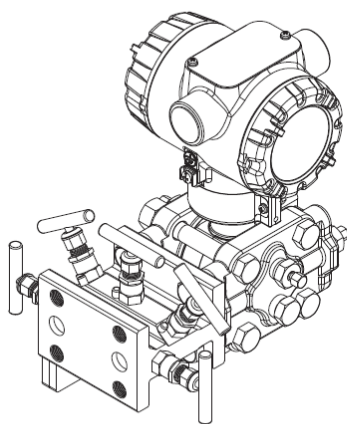
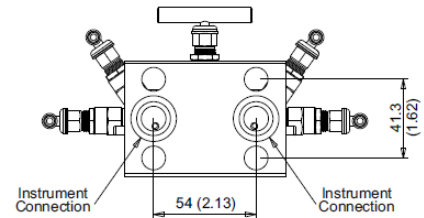
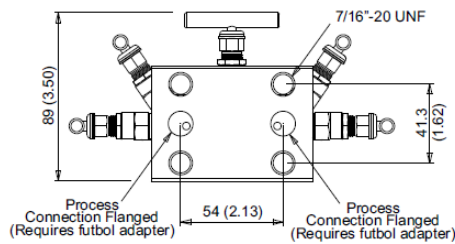
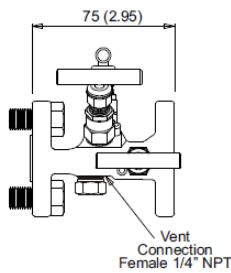

Approximate Weight of Mounting Bracket: 0.70 kg (1.54 lbs.)

Refer to Table 3 in [Model Selection Guide](#) for Mounting Bracket Options.

5 Valve Wide Body Manifold (Flange X Flange) with Bleed Port at Front

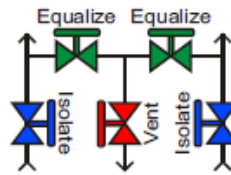
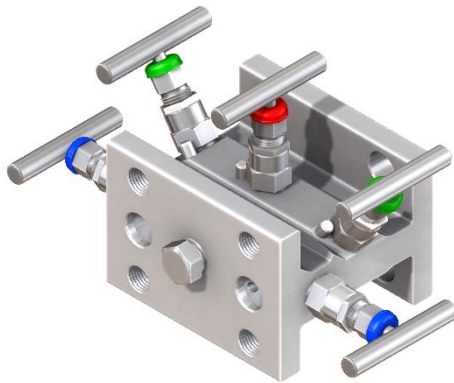

Process connection:
Flanged
Transmitter Connection:
Flanged
Vent/ Bleed / Drain Location:
Front
Approximate Weight:
1.85 kg (4.07 lbs.)
MSG Option:
STMD5 – U _ _

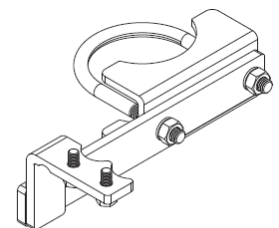
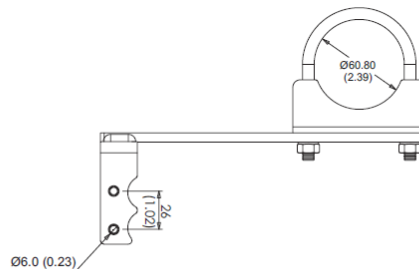
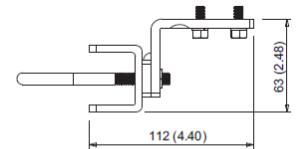
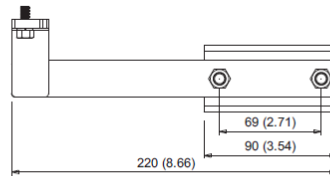
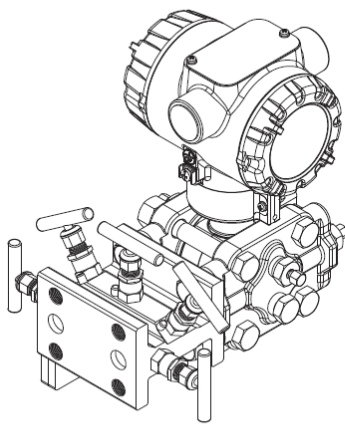
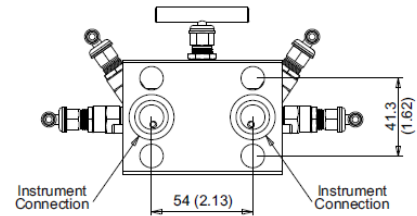
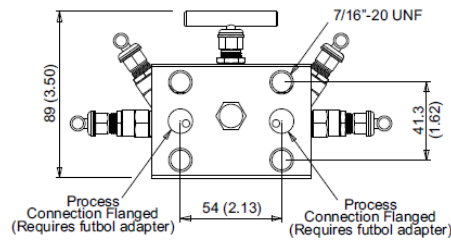
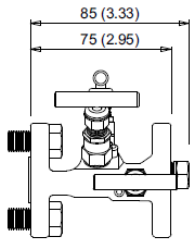

Approximate Weight of Mounting Bracket: 0.70 kg (1.54 lbs.)
 Refer to Table 3 in [Model Selection Guide](#) for Mounting Bracket Options.

Manifold Section - Preference Z

All designs are available with anti-tamper taps. An anti-tamper key (see Accessories list) shall be ordered separately whenever manifolds are ordered with anti-tamper taps.

Single Block and Bleed Manifolds

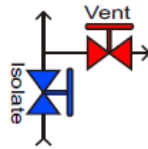
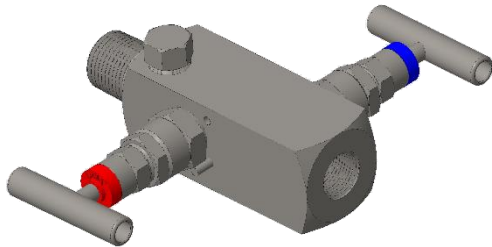

Process connection:
 1/2" NPT Female
Transmitter Connection:
 1/2" NPT Male
Vent/ Bleed / Drain Location:
 Side
Approximate Weight:
 0.7 kg (1.54 lbs.)

MSG Option:
 STMSB - A _ _

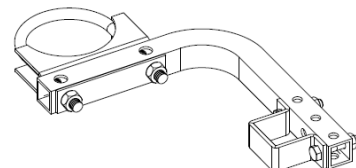
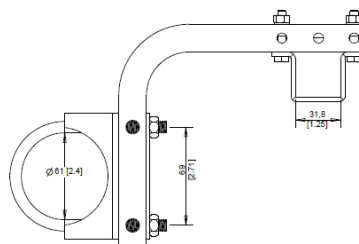
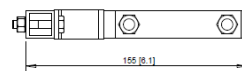
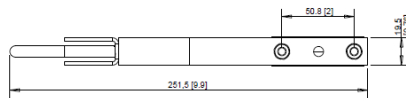
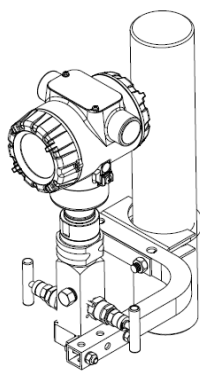
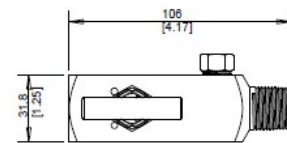
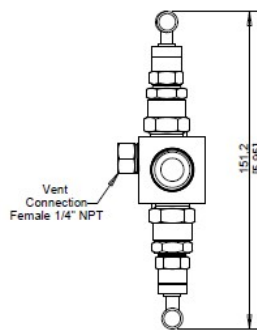
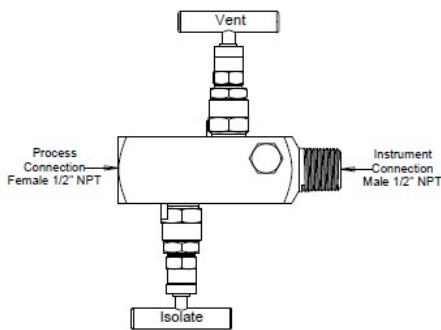

Approximate Weight of Mounting Bracket: 0.70 kg (1.54 lbs.)
 Refer to Table 3 in [Model Selection Guide](#) for Mounting Bracket Options.

Single Block and Bleed Manifolds

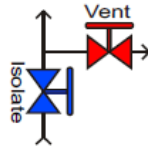
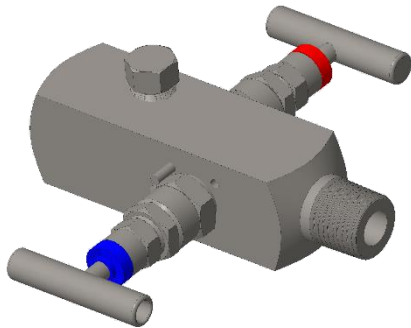

Process connection:
 1/2" NPT Male
Transmitter Connection:
 1/2" NPT Female
Vent/ Bleed / Drain Location:
 Side
Approximate Weight:
 0.9 kg (1.98 lbs.)

MSG Option:
 STMSB - B_ _

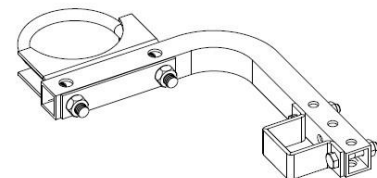
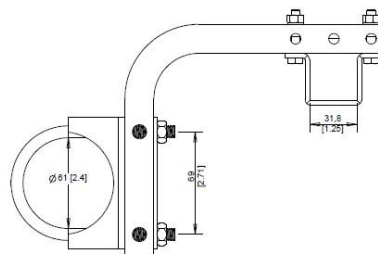
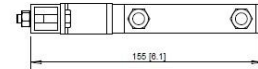
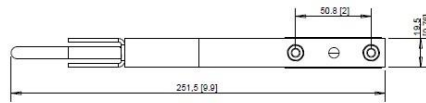
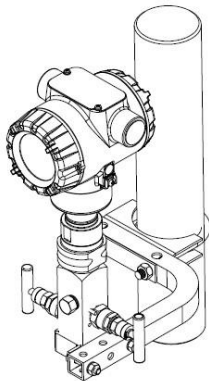
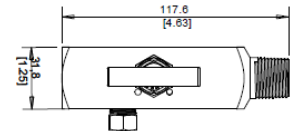
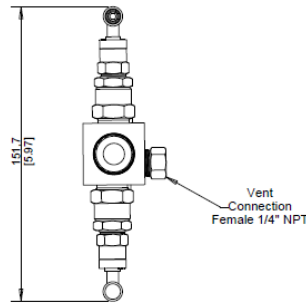
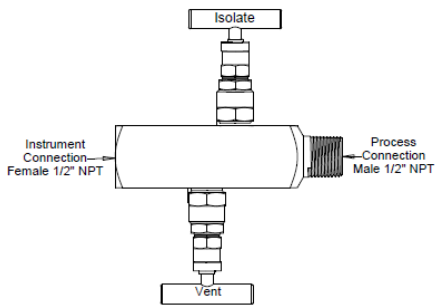

Approximate Weight of Mounting Bracket: 0.70 kg (1.54 lbs.)
 Refer to Table 3 in [Model Selection Guide](#) for Mounting Bracket Options.

Single Block and Bleed Manifolds

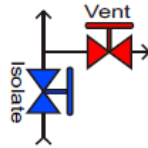
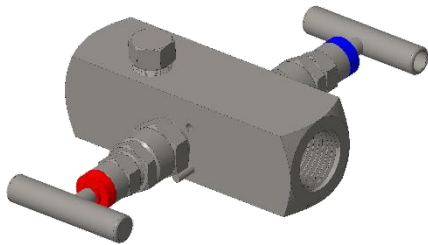

Process connection:
 1/2" NPT Female
Transmitter Connection:
 1/2" NPT Female
Vent/ Bleed / Drain Location:
 Side
Approximate Weight:
 0.65 kg (1.43 lbs.)

MSG Option:
 STMSB - C _ _

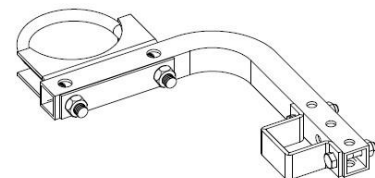
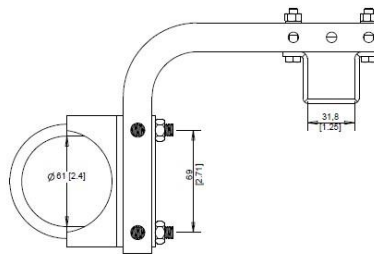
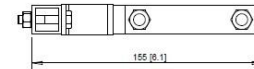
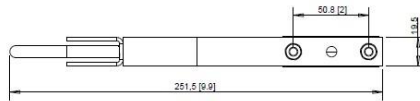
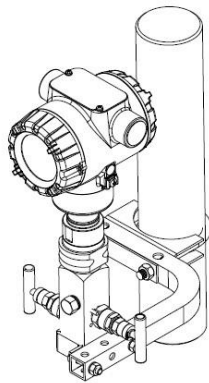
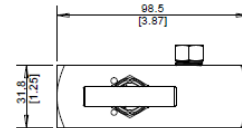
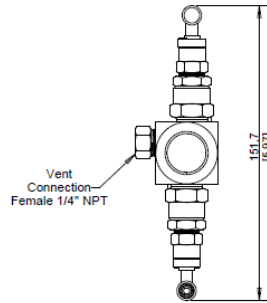
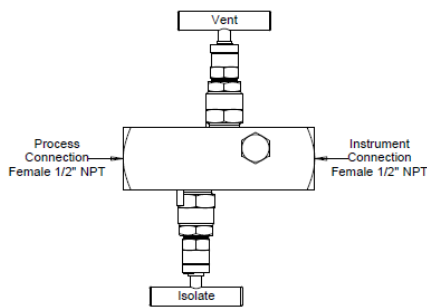

Approximate Weight of Mounting Bracket: 0.70 kg (1.54 lbs.)
 Refer to Table 3 in [Model Selection Guide](#) for Mounting Bracket Options.

Double Block and Bleed Manifolds

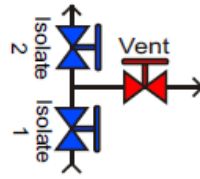
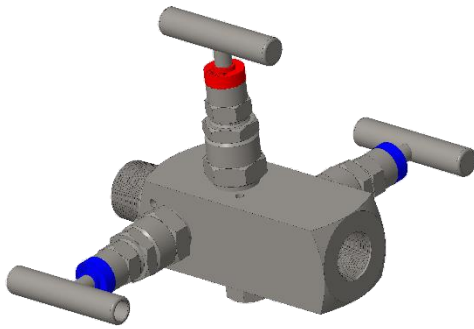

Process connection:

1/2" NPT Female

Transmitter Connection:

1/2" NPT Male

Vent/ Bleed / Drain Location:

Side

Approximate Weight:

1.1 kg (2.42 lbs.)

MSG Option:

STMDB - A_ _

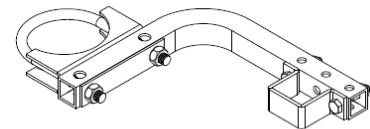
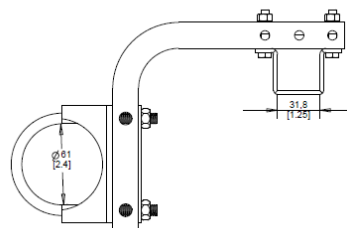
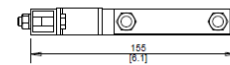
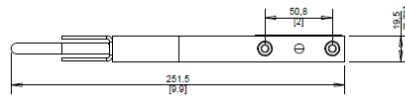
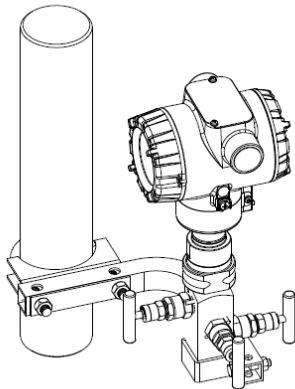
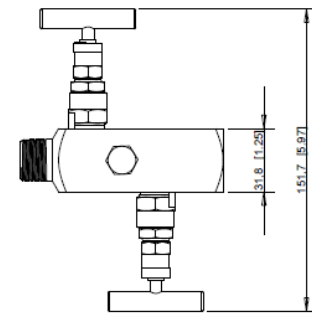
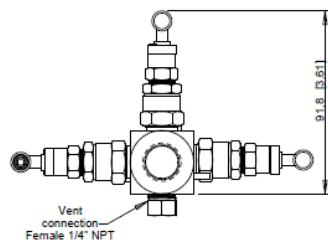
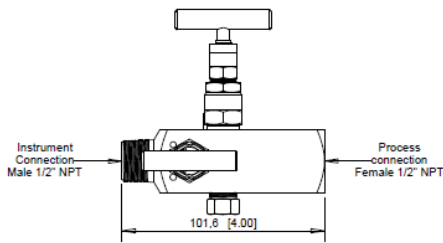

Approximate Weight of Mounting Bracket: 0.70 kg (1.54 lbs.)

Refer to Table 3 in [Model Selection Guide](#) for Mounting Bracket Options.

Double Block and Bleed Manifolds

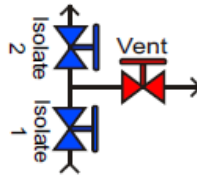
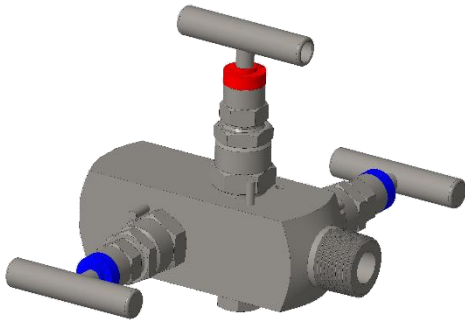

Process connection:

1/2" NPT Male

Transmitter Connection:

1/2" NPT Female

Vent/ Bleed / Drain Location:

Side

Approximate Weight:

1.1 kg (2.42 lbs.)

MSG Option:

STMDB - B_ _

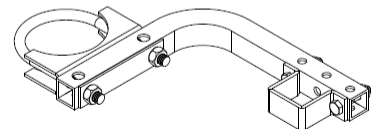
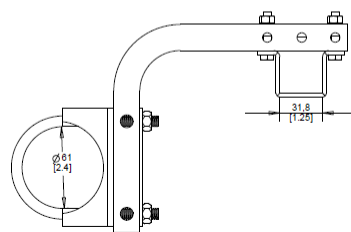
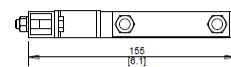
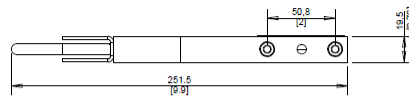
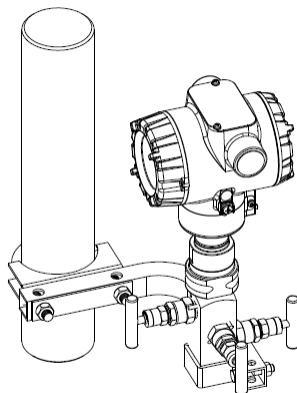
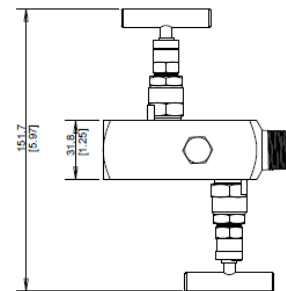
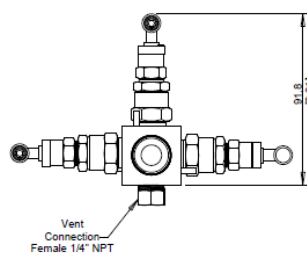
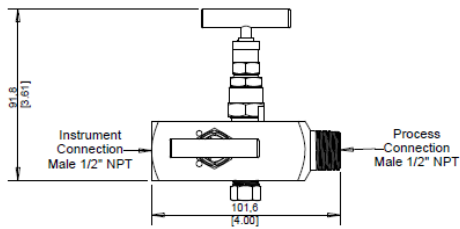

Approximate Weight of Mounting Bracket: 0.70 kg (1.54 lbs.)

Refer to Table 3 in [Model Selection Guide](#) for Mounting Bracket Options.

Double Block and Bleed Manifolds

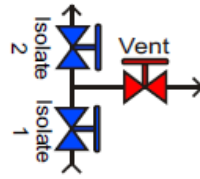
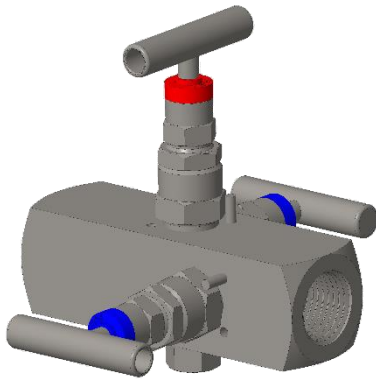

Process connection:

1/2" NPT Female

Transmitter Connection:

1/2" NPT Female

Vent/ Bleed / Drain Location:

Side

Approximate Weight:

1.1 kg (2.42 lbs.)

MSG Option:

STMDB - C_ _

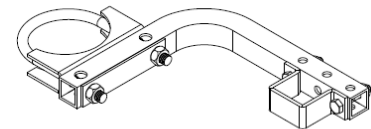
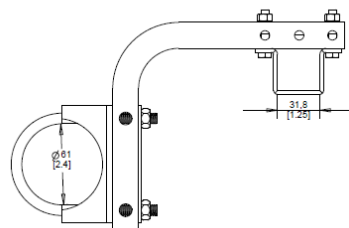
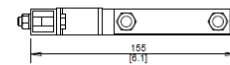
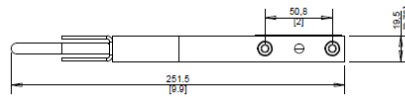
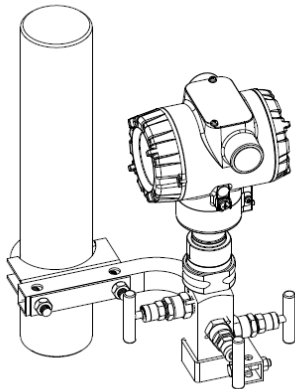
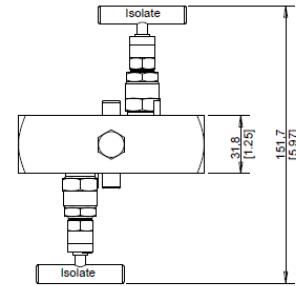
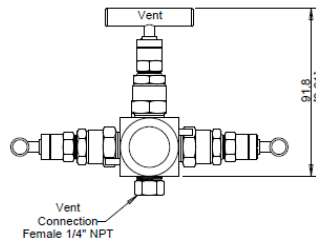
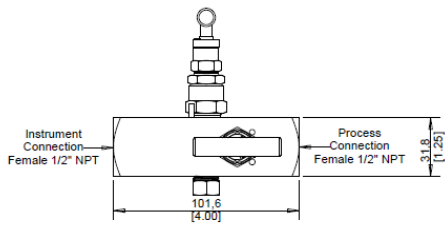

Approximate Weight of Mounting Bracket: 0.70 kg (1.54 lbs.)

Refer to Table 3 in [Model Selection Guide](#) for Mounting Bracket Options.

2 Valve Wide Liquid Level Manifold

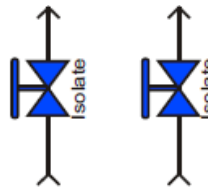
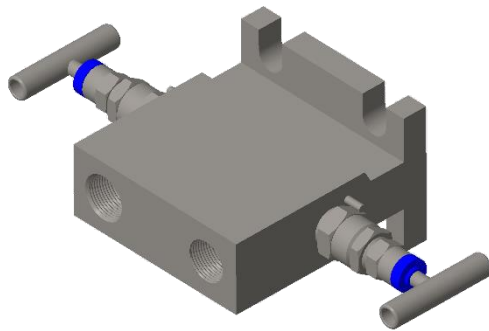

Process connection:

1/2" NPT Female

Transmitter Connection:

Flanged

Vent/ Bleed / Drain Location:

N/A

Approximate Weight:

2.1 kg (4.62 lbs.)

MSG Option:

STMD2 - D_ _

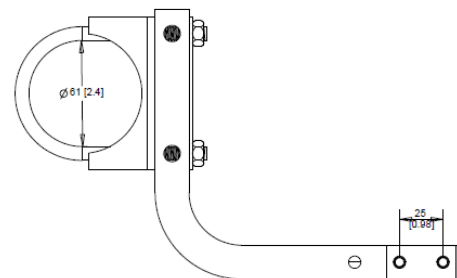
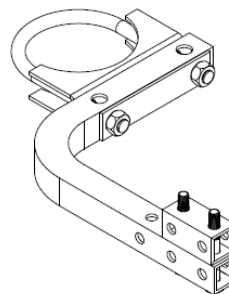
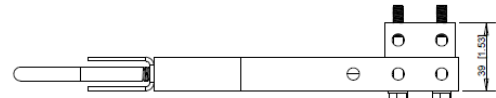
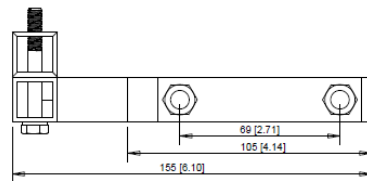
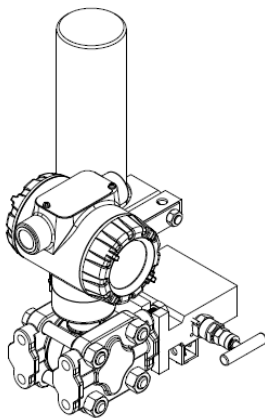
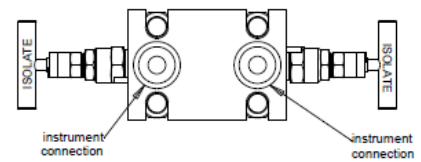
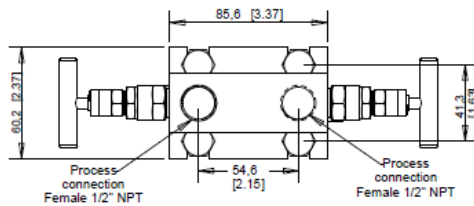
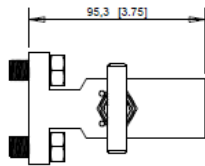

Approximate Weight of Mounting Bracket: 0.70 kg (1.54 lbs.)

Refer to Table 3 in [Model Selection Guide](#) for Mounting Bracket Options.

2 Valve Compact Body Manifold

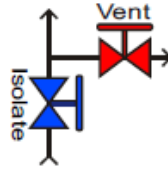
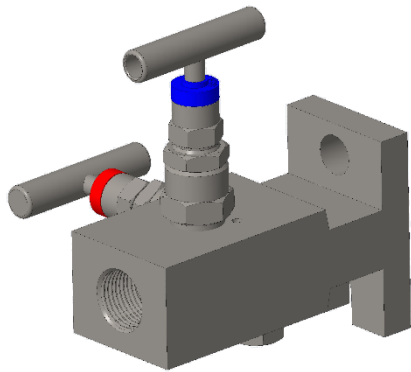

Process connection:

1/2" NPT Female

Transmitter Connection:

Flanged

Vent/ Bleed / Drain Location:

Bottom

Approximate Weight:

1.3 kg (2.86 lbs.)

MSG Option:

STMD2 - E _ _

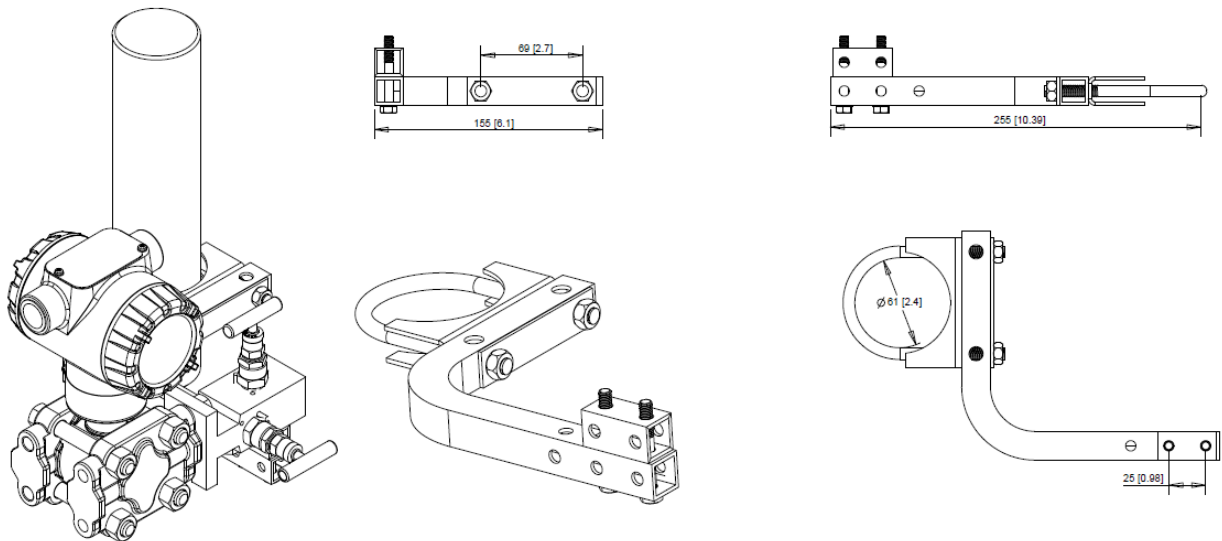
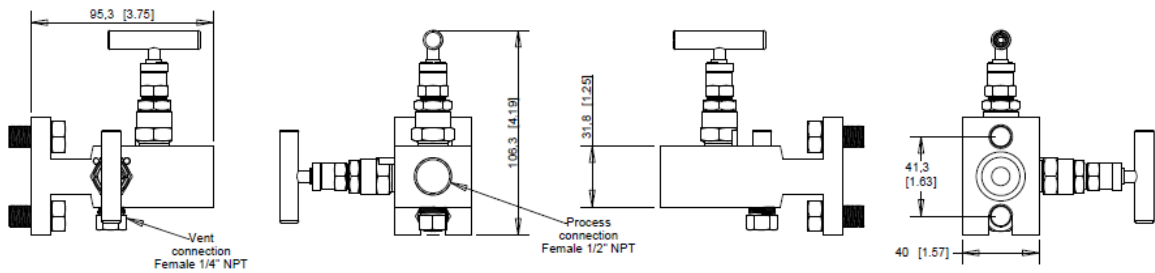

Approximate Weight of Mounting Bracket: 0.70 kg (1.54 lbs.)

Refer to Table 3 in [Model Selection Guide](#) for Mounting Bracket Options.

2 Valve Wide Body Manifold

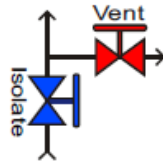
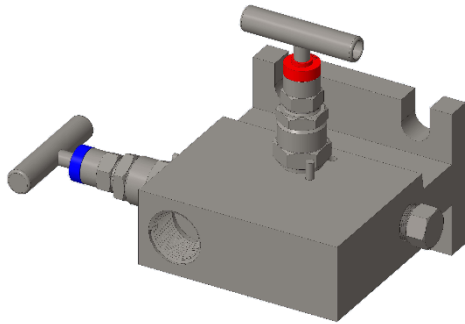

Process connection:
 1/2" NPT Female
Transmitter Connection:
 Flanged
Vent/ Bleed / Drain Location:
 Side
Approximate Weight:
 2.1 kg (4.62 lbs.)
MSG Option:
 STMD2 - F _ _

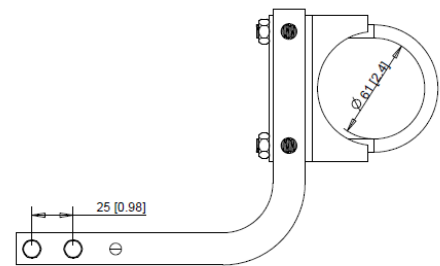
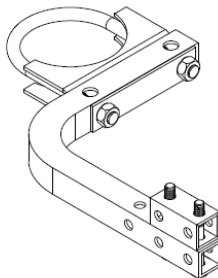
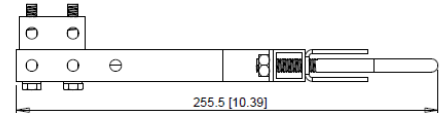
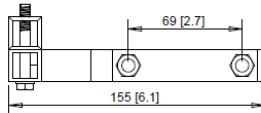
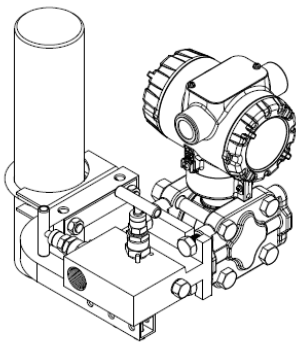
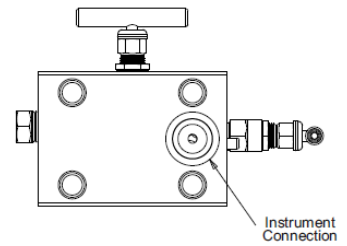
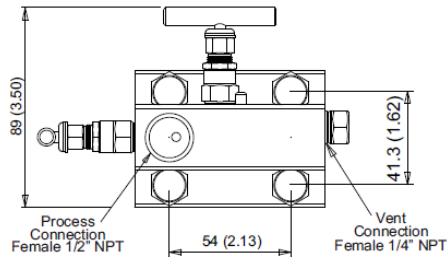
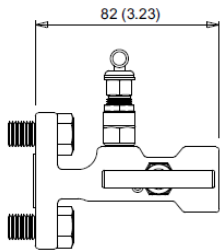

Approximate Weight of Mounting Bracket: 0.70 kg (1.54 lbs.)
 Refer to Table 3 in [Model Selection Guide](#) for Mounting Bracket Options.

2 Valve Wafer Style Manifold

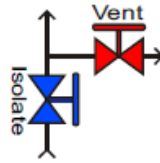
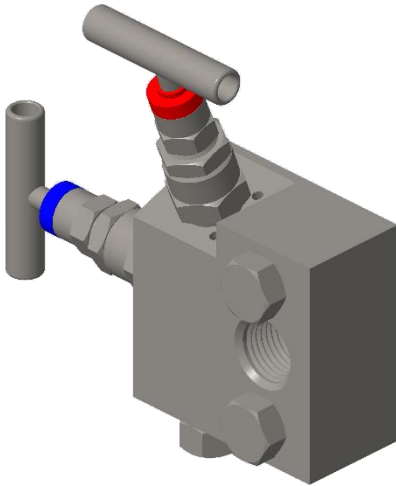

Process connection:
 ½" NPT Female
Transmitter Connection:
 Flanged
Vent/ Bleed / Drain Location:
 Bottom
Approximate Weight:
 0.95 kg (2.09 lbs.)

MSG Option:
 STMD2 - G _ _

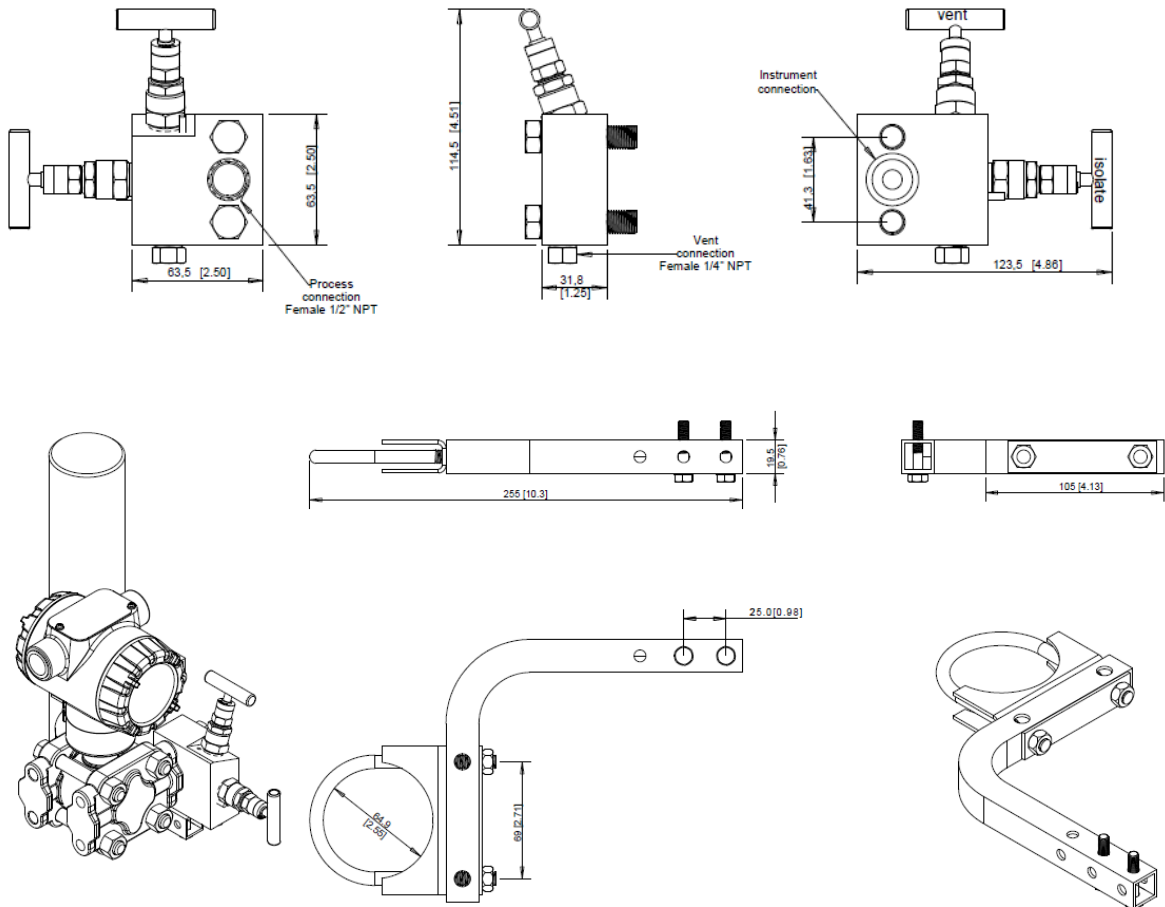

Approximate Weight of Mounting Bracket: 0.70 kg (1.54 lbs.)
 Refer to Table 3 in [Model Selection Guide](#) for Mounting Bracket Options.

2 Valve Compact Body Manifold (Flange X Flange)

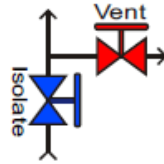
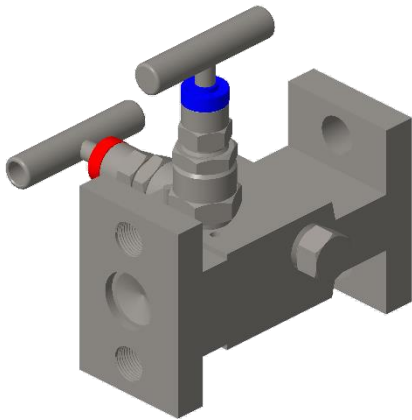

Process connection:
Flanged
Transmitter Connection:
Flanged
Vent/ Bleed / Drain Location:
Side
Approximate Weight:
1.4 kg (3.08 lbs.)

MSG Option:
STMD2 - H _ _

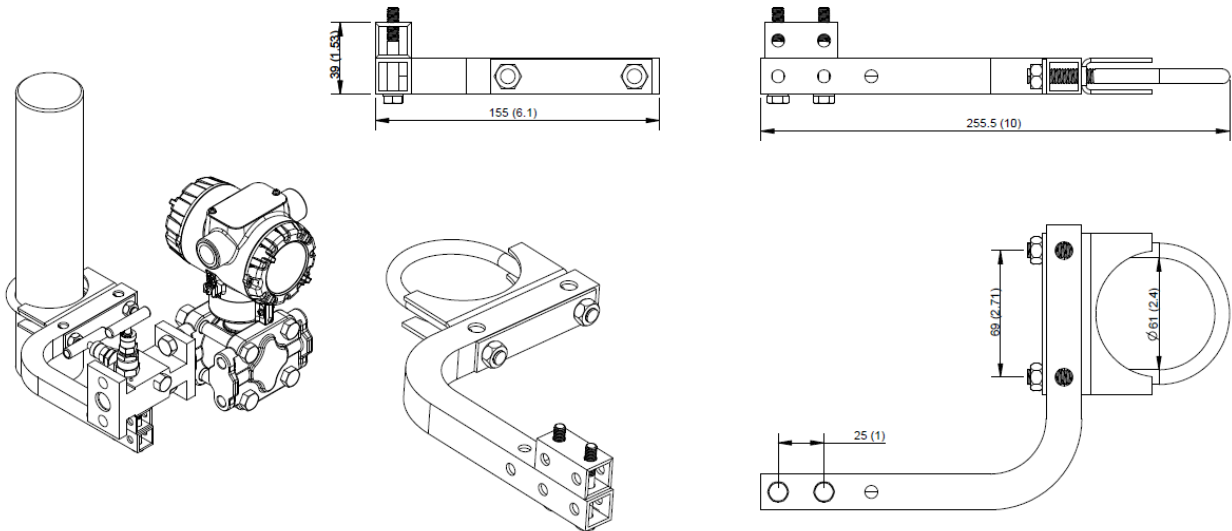
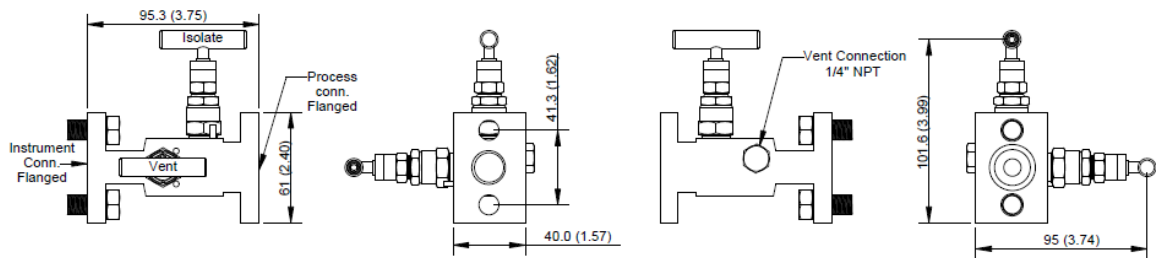

Approximate Weight of Mounting Bracket: 0.70 kg (1.54 lbs.)
Refer to Table 3 in [Model Selection Guide](#) for Mounting Bracket Options.

2 Valve Wide Body Manifold (Flange X Flange)

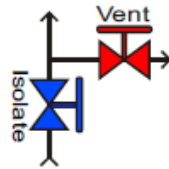
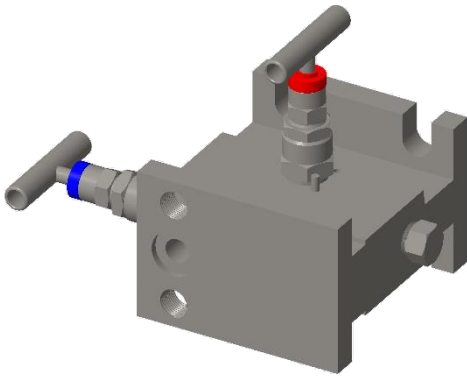

Process connection:
Flanged
Transmitter Connection:
Flanged
Vent/ Bleed / Drain Location:
Side
Approximate Weight:
2.2 kg (4.84 lbs.)

MSG Option:
STMD2 - J __

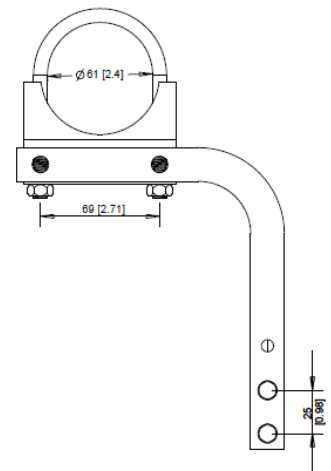
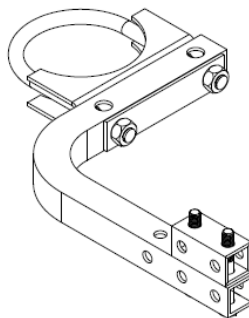
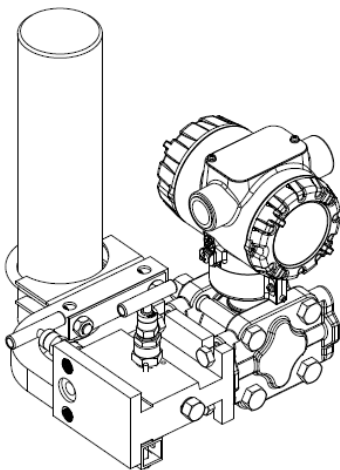
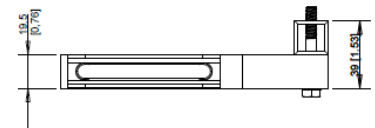
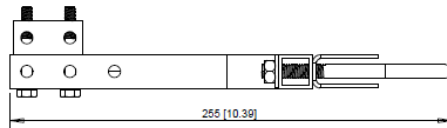
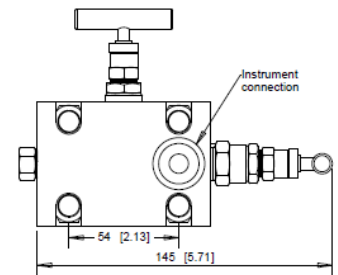
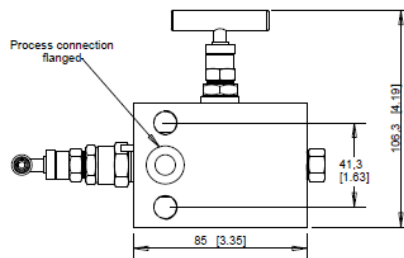
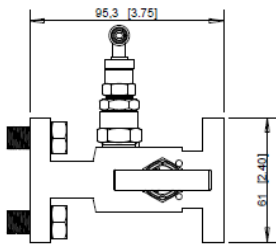

Approximate Weight of Mounting Bracket: 0.70 kg (1.54 lbs.)
Refer to Table 3 in [Model Selection Guide](#) for Mounting Bracket Options.

3 Valve Wide Body Manifold

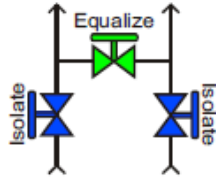
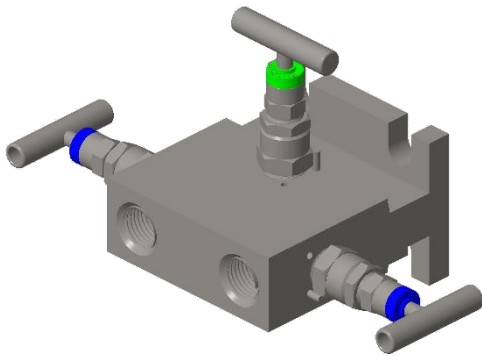

Process connection:
 1/2" NPT Female
Transmitter Connection:
 Flanged
Vent/ Bleed / Drain Location:
 N/A
Approximate Weight:
 2.3 kg (5.06 lbs.)
MSG Option:
 STMD3 - K _ _

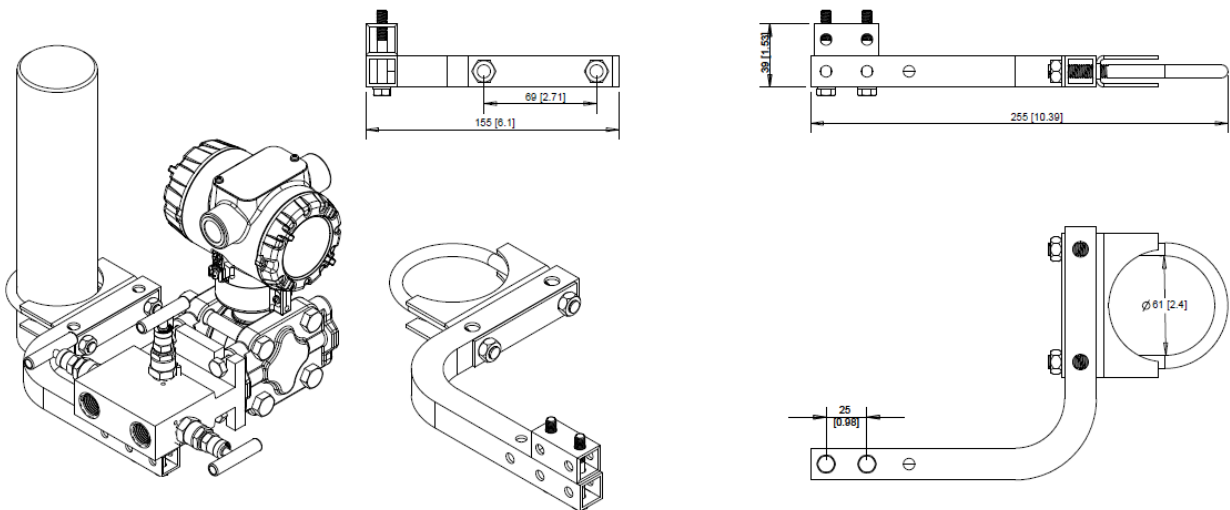
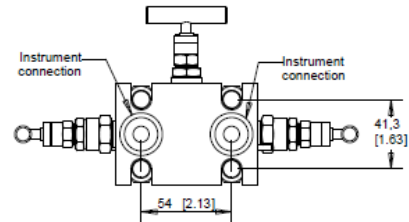
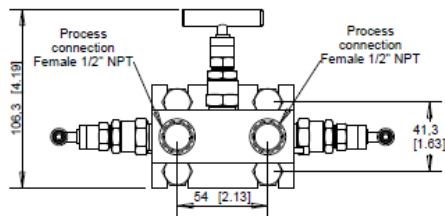
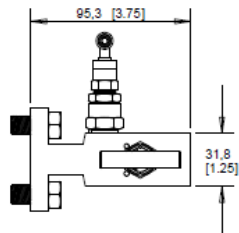

Approximate Weight of Mounting Bracket: 0.70 kg (1.54 lbs.)
 Refer to Table 3 in [Model Selection Guide](#) for Mounting Bracket Options.

3 Valve Wide Body Manifold with Bleed Ports

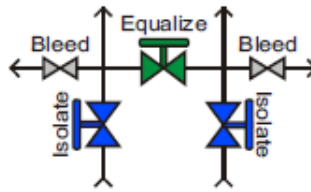
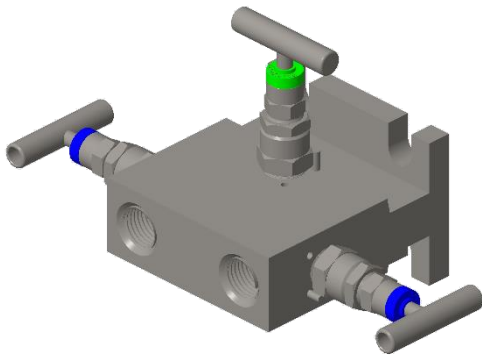

Process connection:
 1/2" NPT Female
Transmitter Connection:
 Flanged
Vent/ Bleed / Drain Location:
 Bottom
Approximate Weight:
 2.3 kg (5.06 lbs.)
MSG Option:
 STMD3 - L _ _

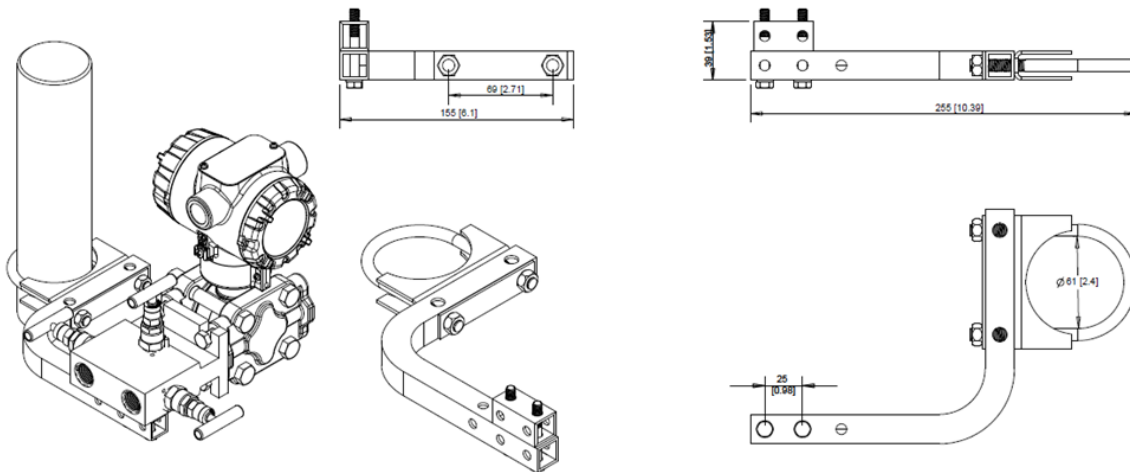
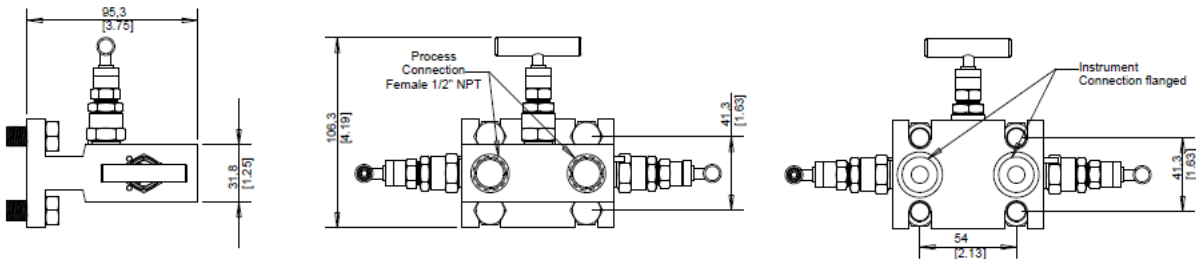

Approximate Weight of Mounting Bracket: 0.70 kg (1.54 lbs.)
 Refer to Table 3 in [Model Selection Guide](#) for Mounting Bracket Options.

3 Valve Wafer Style Manifold

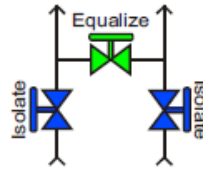
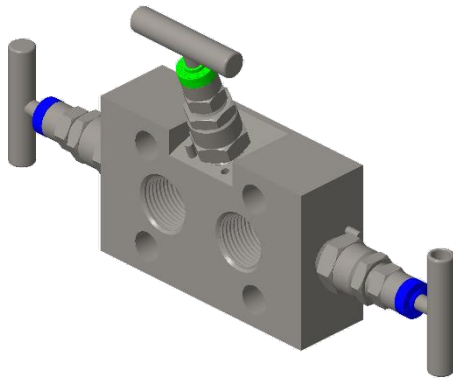

Process connection:
 1/2" NPT Female
Transmitter Connection:
 Flanged
Vent/ Bleed / Drain Location:
 N/A
Approximate Weight:
 1.6 kg (3.52 lbs.)

MSG Option:
 STMD3 - M _ _

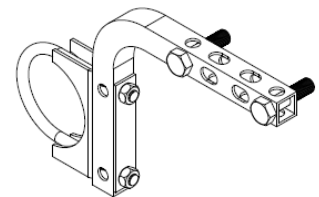
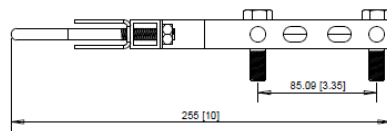
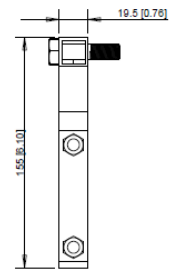
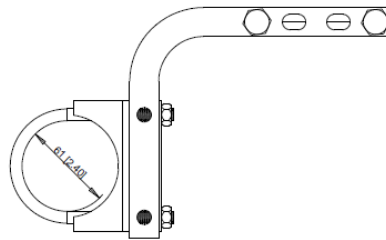
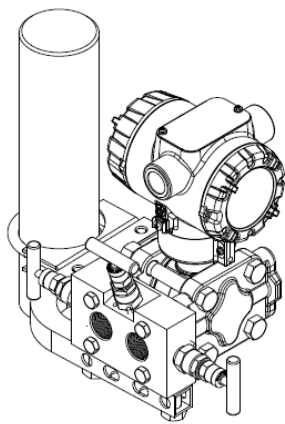
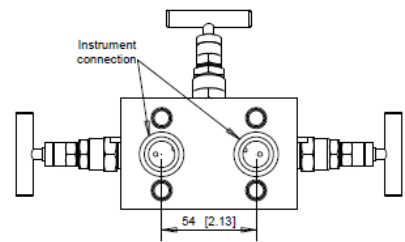
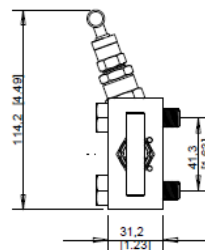
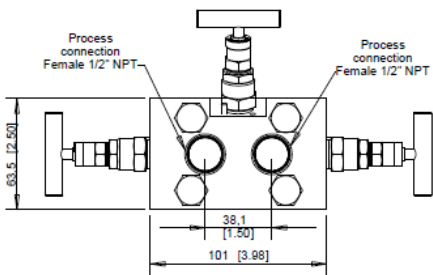

Approximate Weight of Mounting Bracket: 0.90 kg (1.98 lbs.)
 Refer to Table 3 in [Model Selection Guide](#) for Mounting Bracket Options.

3 Valve Wafer Style Manifold with Bleed Ports

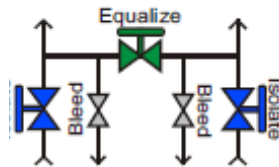
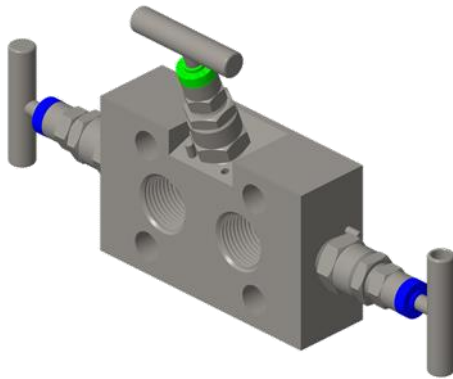

Process connection:
 1/2" NPT Female
Transmitter Connection:
 Flanged
Vent/ Bleed / Drain Location:
 Bottom
Approximate Weight:
 1.7 kg (3.74 lbs.)

MSG Option:
 STMD3 - N _ _

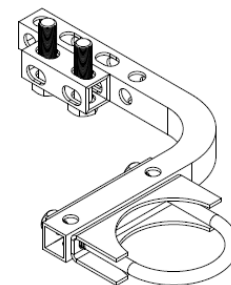
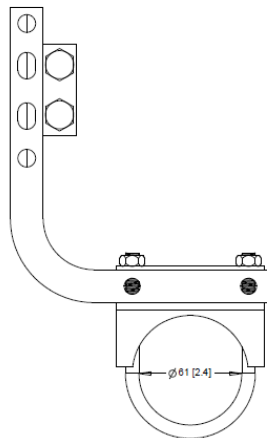
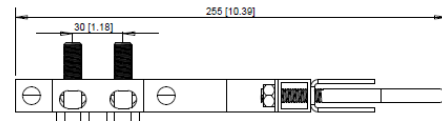
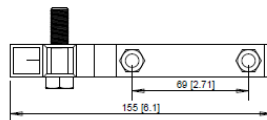
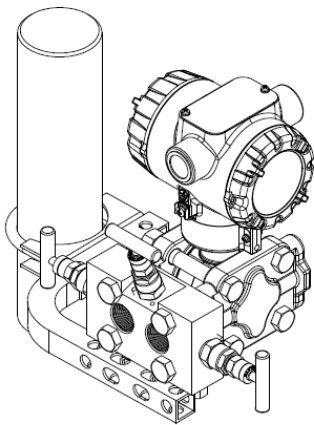
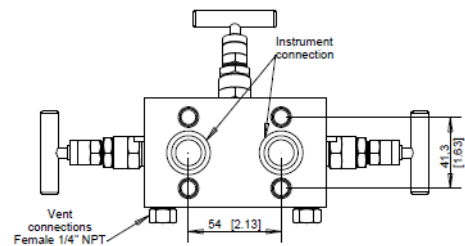
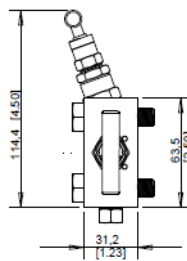
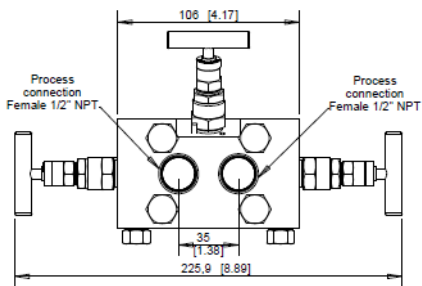

Approximate Weight of Mounting Bracket: 0.71 kg (1.56 lbs.)
 Refer to Table 3 in [Model Selection Guide](#) for Mounting Bracket Options.

3 Valve Wide Body Manifold (Flange X Flange)

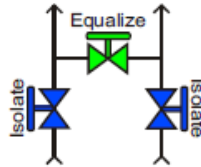
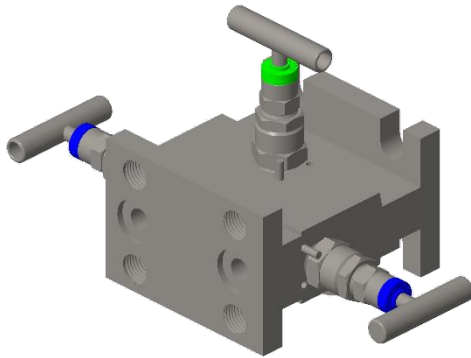

Process connection:
Flanged
Transmitter Connection:
Flanged
Vent/ Bleed / Drain Location:
N/A
Approximate Weight:
2.4 kg (5.28 lbs.)
MSG Option:
STMD3 - O _ _

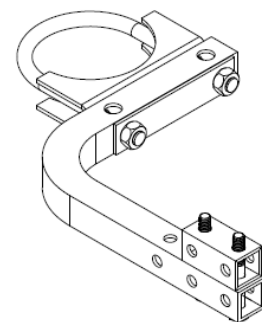
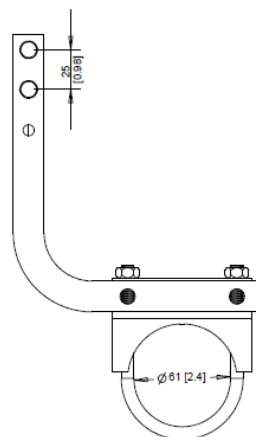
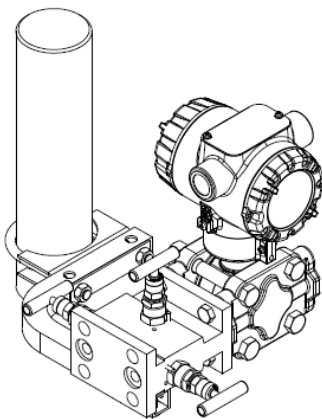
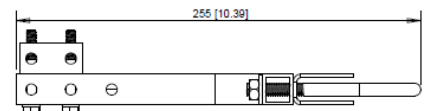
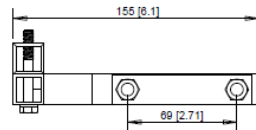
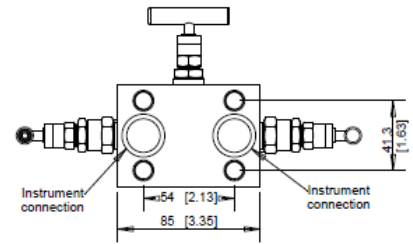
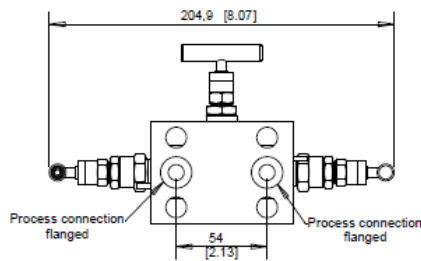
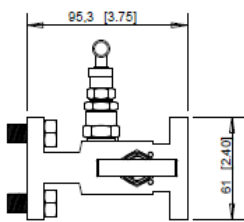

Approximate Weight of Mounting Bracket: 0.70 kg (1.54 lbs.)
 Refer to Table 3 in [Model Selection Guide](#) for Mounting Bracket Options.

3 Valve Wide Body Manifold (Flange X Flange) with Bleed Ports

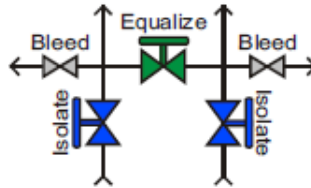
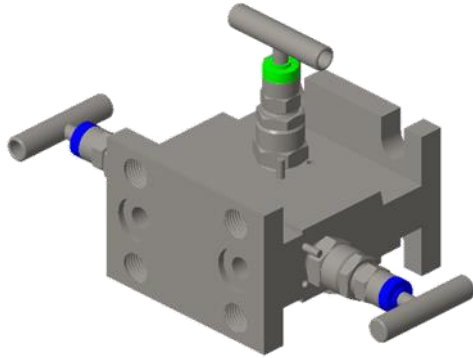

Process connection:
Flanged
Transmitter Connection:
Flanged
Vent/ Bleed / Drain Location:
Bottom
Approximate Weight:
2.4 kg (5.28 lbs.)

MSG Option:
STMD3 - P _ _

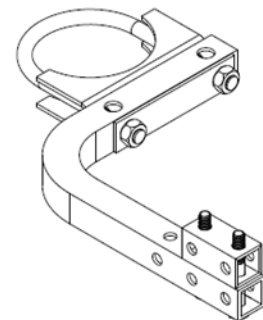
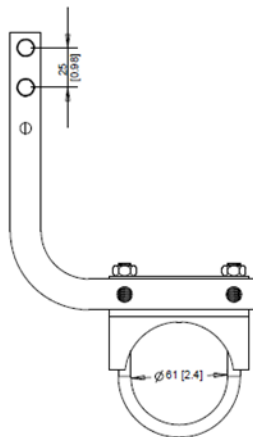
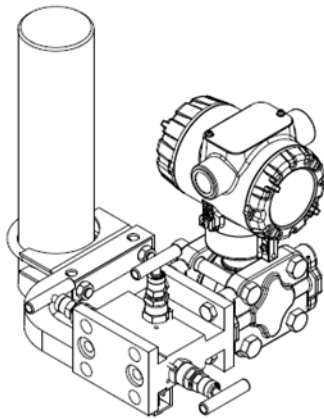
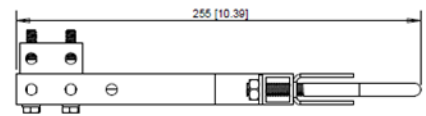
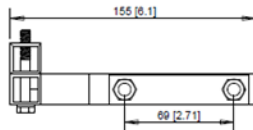
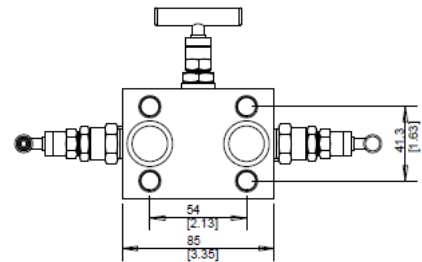
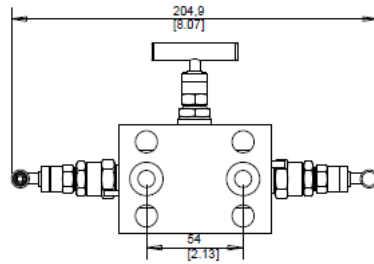
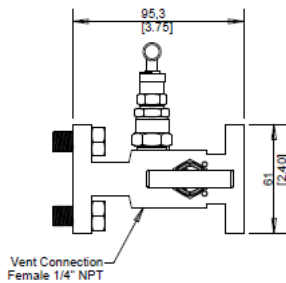

Approximate Weight of Mounting Bracket: 0.70 kg (1.54 lbs.)
Refer to Table 3 in [Model Selection Guide](#) for Mounting Bracket Options.

5 Valve Wide Body Manifold with Bleed Port at Bottom

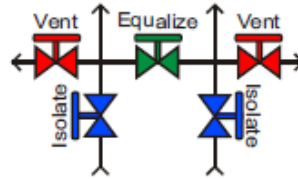
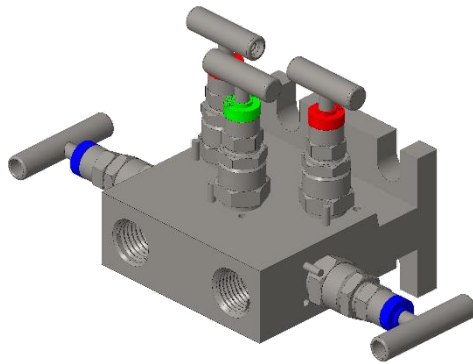

Process connection:
 1/2" NPT Female
Transmitter Connection:
 Flanged
Vent/ Bleed / Drain Location:
 Bottom
Approximate Weight:
 2.4 kg (5.28 lbs.)

MSG Option:
 STMD5 - Q _ _

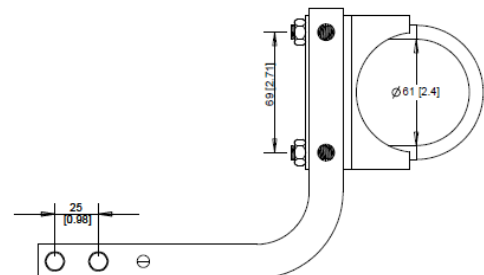
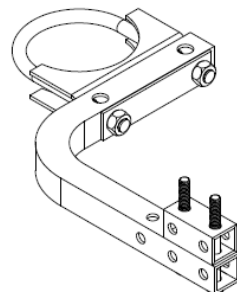
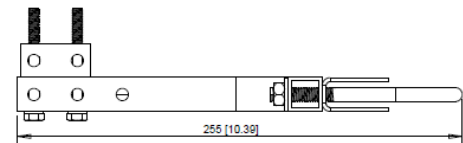
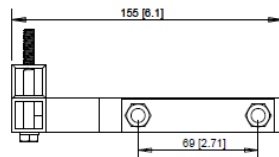
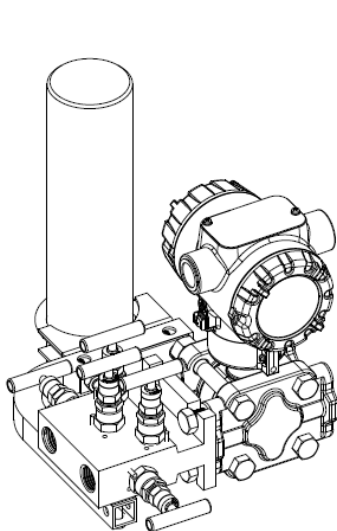
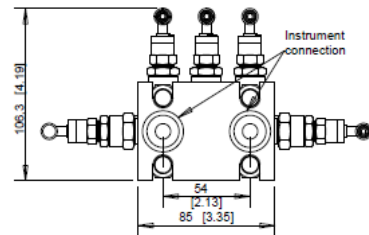
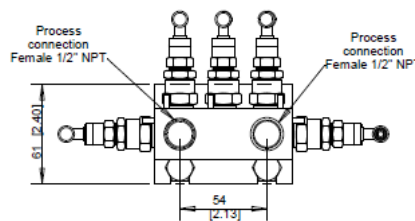
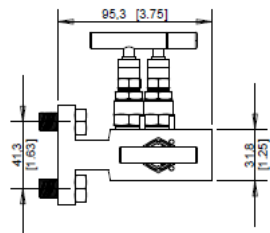

Approximate Weight of Mounting Bracket: 0.70 kg (1.54 lbs.)
 Refer to Table 3 in [Model Selection Guide](#) for Mounting Bracket Options.

5 Valve Wide Body Manifold with Bleed Port at Front

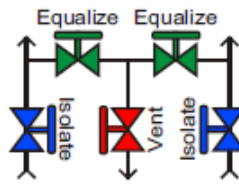
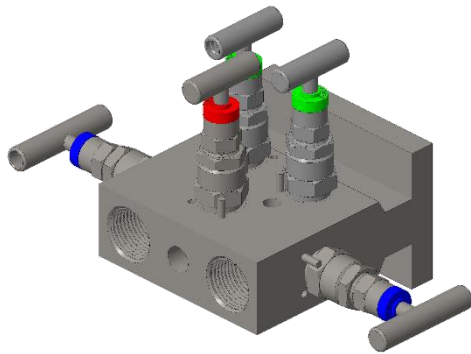

Process connection:
 1/2" NPT Female
Transmitter Connection:
 Flanged
Vent/ Bleed / Drain Location:
 Bottom
Approximate Weight:
 2.4 kg (5.28 lbs.)
MSG Option:
 STMD5 - R _ _

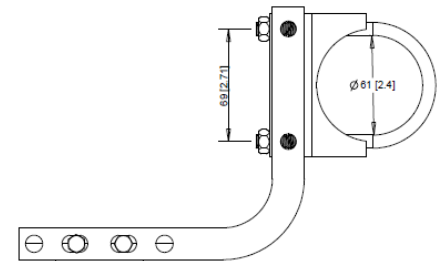
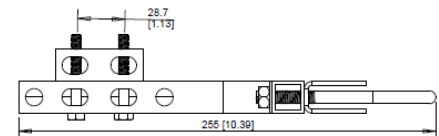
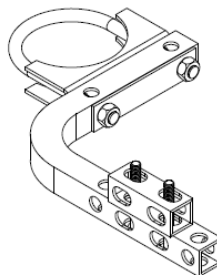
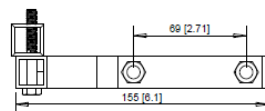
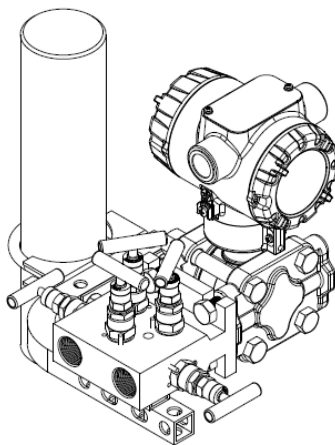
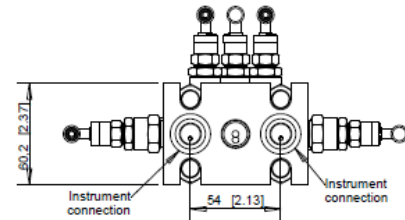
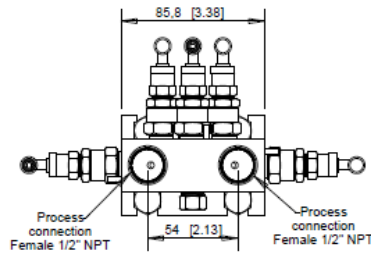
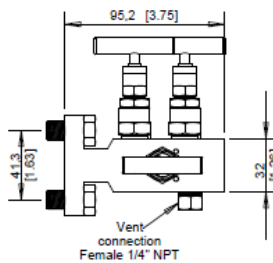

Approximate Weight of Mounting Bracket: 0.71 kg (1.56 lbs.)
 Refer to Table 3 in [Model Selection Guide](#) for Mounting Bracket Options.

5 Valve Wafer Style Manifold

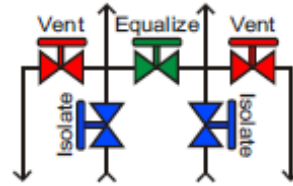
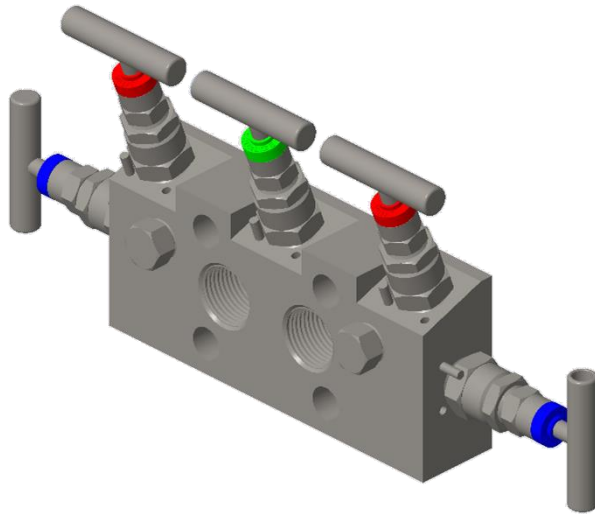

Process connection:
 ½" NPT Female
Transmitter Connection:
 Flanged
Vent/ Bleed / Drain
 Location:
 Front
Approximate Weight:
 2.5 kg (5.5 lbs.)

MSG Option:
 STMD5 - S _ _

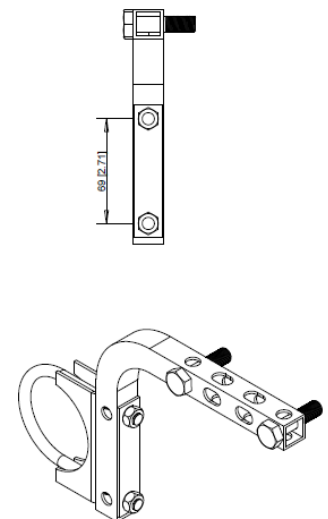
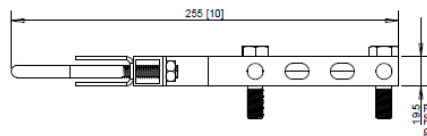
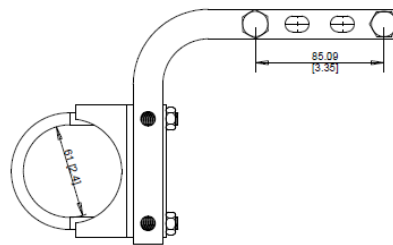
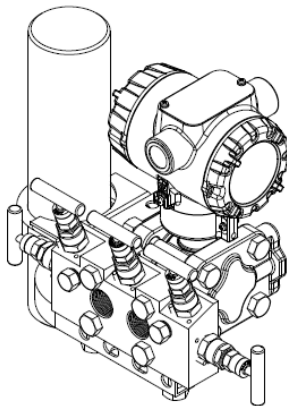
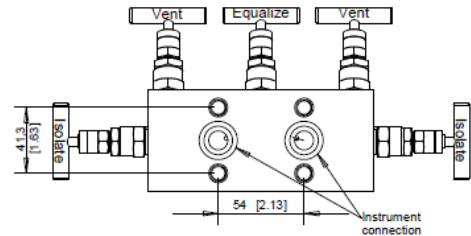
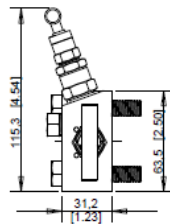
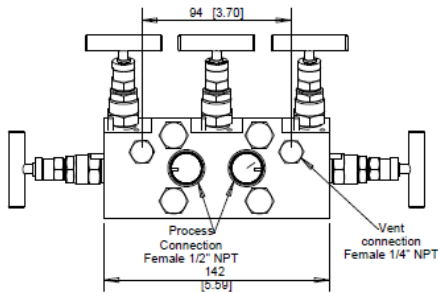

Approximate Weight of Mounting Bracket: 0.90 kg (1.98 lbs.)
 Refer to Table 3 in [Model Selection Guide](#) for Mounting Bracket Options.

5 Valve Wide Body Manifold (Flange X Flange) with Bleed Port at Bottom

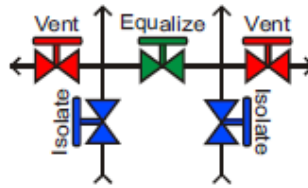
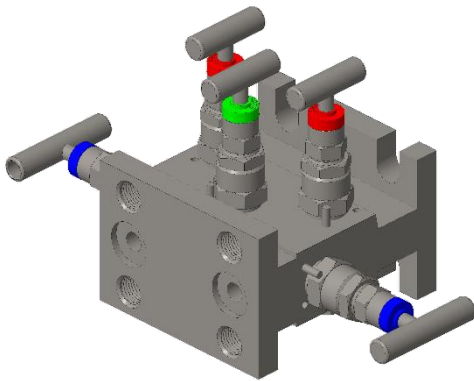

Process connection:

Flanged

Transmitter Connection:

Flanged

Vent/ Bleed / Drain Location:

Bottom

Approximate Weight:

2.6 kg (5.72 lbs.)

MSG Option:

STMD5 - T __

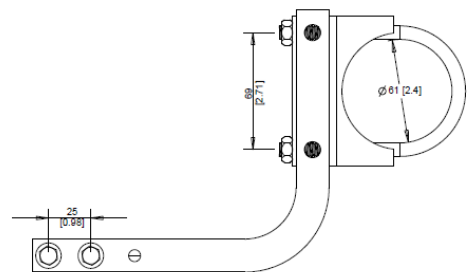
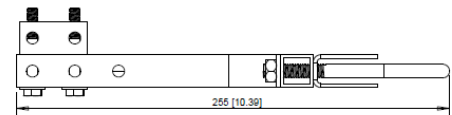
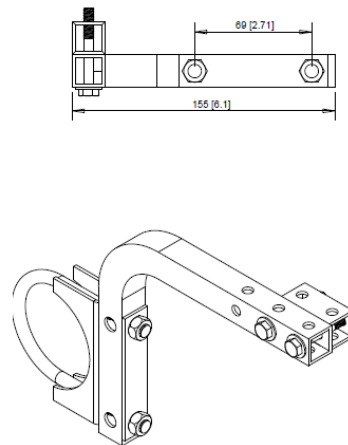
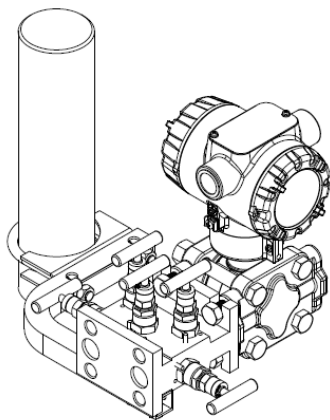
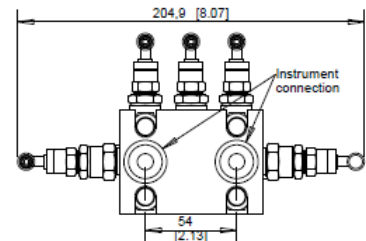
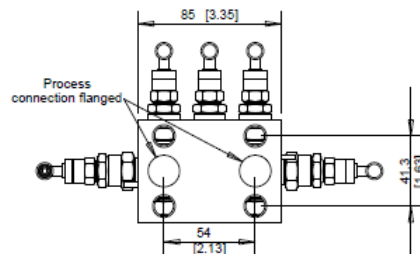
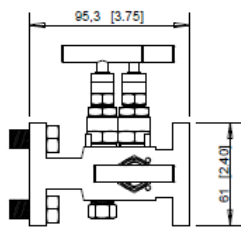

Approximate Weight of Mounting Bracket: 0.70 kg (1.54 lbs.)

Refer to Table 3 in [Model Selection Guide](#) for Mounting Bracket Options.

5 Valve Wide Body Manifold (Flange X Flange) with Bleed Port at Front

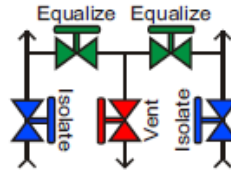
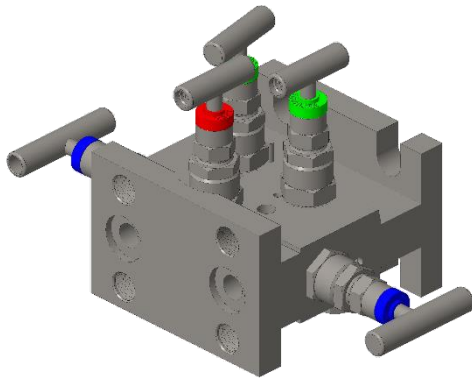

Process connection:
Flanged
Transmitter Connection:
Flanged
Vent/ Bleed / Drain Location:
Bottom
Approximate Weight:
2.6 kg (5.72 lbs.)
MSG Option:
STMD5 - U _ _

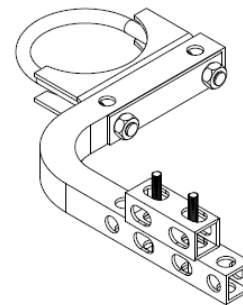
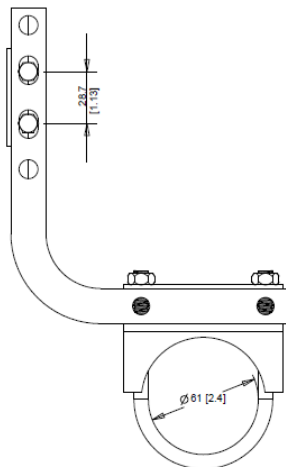
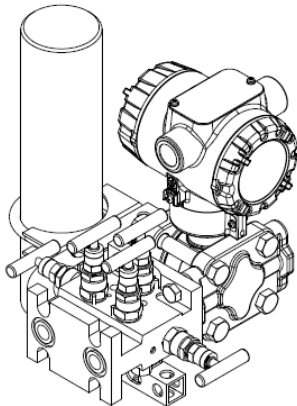
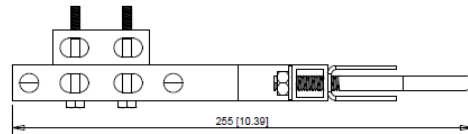
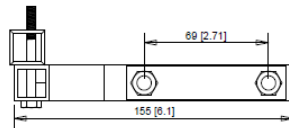
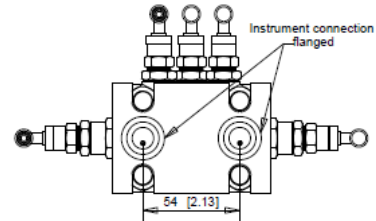
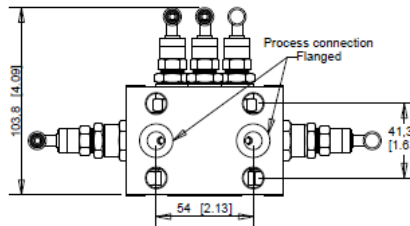
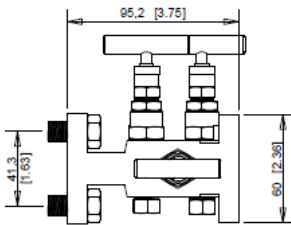

Approximate Weight of Mounting Bracket: 0.70 kg (1.54 lbs.)
 Refer to Table 3 in [Model Selection Guide](#) for Mounting Bracket Options.

Model Selection Guide

Model STM
SmartLine Manifolds

Model Selection Guide: Issue no
34-ST-16-126 10

Instructions: Make selections from all Tables Key through V using column below the proper arrow. Asterisk indicates availability. Letter (a) refer to restrictions highlighted in the restrictions table. Tables delimited with dashes. List Price: Price equals the sum of prices for all selections made.

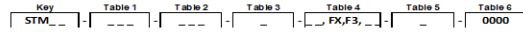

Key Number	Description	For transmitters
Manifold type	2 valve single block and bleed	Inline
	2 valve double block and bleed	Inline
	2 valve Manifold	Dual Head
	3 valve Manifold	Dual Head
	5 valve Manifold	Dual Head

Selection	Availability
STMSB	↓
STMDB	↓
STMD2	↓
STMD3	↓
STMD5	↓

Table 1		Manifold Style and Configuration				
		Body Type	Process connection	Transmitter connection	Vent/Bleed/Drain Location(Note 3)	
a. Manifold configuration	INLINE AP AND GP ONLY	Block & Bleed (single or double blocks)	1/2" NPT (Female)	1/2" NPT (Male)	Side	
		Block & Bleed (single or double blocks)	1/2" NPT (Male)	1/2" NPT (Female)	Side	
		Block & Bleed (single or double blocks)	1/2" NPT (Female)	1/2" NPT (Female)	Side	
	DP ONLY	Wide(Liquid level)	1/2" NPT (Female)	Flanged (Note 7)	NA	
		DHAP AND DHGP ONLY	Compact	1/2" NPT (Female)	Flanged (Note 7)	Bottom
			Wide	1/2" NPTF	Flanged (Note 7)	Side
	Wafer		1/2" NPT (Female)	Flanged	Bottom	
	DP ONLY	Compact	Flanged (See Note 8)	Flanged (Note 7)	Side	
		Wide	Flanged (See Note 8)	Flanged (Note 7)	Side	
		Wide	1/2" NPT (Female)	Flanged (Note 7)	NA	
		Wide	1/2" NPT (Female)	Flanged (Note 7)	Bottom	
		Wafer	1/2" NPT (Female)	Flanged	NA	
		Wafer	1/2" NPT (Female)	Flanged	Bottom	
		Wide	Flanged (See Note 8)	Flanged (Note 7)	NA	
		Wide	Flanged (See Note 8)	Flanged (Note 7)	Bottom	
		Wide	1/2" NPT (Female)	Flanged (Note 7)	Bottom	
		Wide	1/2" NPT (Female)	Flanged (Note 7)	Front/ Bottom (Note 9)	
		Wafer	1/2" NPT (Female)	Flanged	Front	
Wide		Flanged (See Note 8)	Flanged (Note 7)	Bottom		
Wide	Flanged (See Note 8)	Flanged (Note 7)	Front/ Bottom (Note 9)			

A	*	*	*	*	*
B	*	*	*	*	*
C	*	*	*	*	*
D	*	*	*	*	*
E	*	*	*	*	*
F	*	*	*	*	*
G	*	*	*	*	*
H	*	*	*	*	*
J	*	*	*	*	*
K	*	*	*	*	*
L	*	*	*	*	*
M	*	*	*	*	*
N	*	*	*	*	*
O	*	*	*	*	*
P	*	*	*	*	*
Q	*	*	*	*	*
R	*	*	*	*	*
S	*	*	*	*	*
T	*	*	*	*	*
U	*	*	*	*	*
1	*	*	*	*	*
2	*	*	*	*	*

b. Packing/ Gasket Material		Tefflon ® (Virgin PTFE) packing and gasket (See Note 4, 5, 6)				
		Grafoil® (Graphite) packing and gasket (See Note 4, 5, 6)				
		Body	Bonnet	Shaft/Stem	Trim	
c. Material of construction	For Preference X	SS 316/316 L Dual certified	SS 316/316 L Dual certified	SS 316/316 L Dual certified	SS 316/316 L Dual certified	
			Hastelloy® C-276*	Hastelloy® C-276*	Hastelloy® C-276*	
			SS 316/316 L Dual certified	Hastelloy® C-276*	Hastelloy® C-276*	
		Carbon Steel (ASTM A105)	CS (ASTM A105)	SS 304	SS 304	
			CS (ASTM A105)	SS 304	Tungsten Carbide Ball	
			Hastelloy® C-276*	Hastelloy® C-276*	Hastelloy® C-276*	
		For Preference Z	SS 316/316 L Dual certified	SS 316/316 L Dual certified	SS 316/316 L Dual certified	SS 316/316 L Dual certified
				Hastelloy® C-276*	SS 316/316 L Dual certified	Hastelloy® C-276*
				SS 316/316 L Dual certified	SS 316/316 L Dual certified	Hastelloy® C-276*
	Carbon Steel (ASTM A108)		CS (ASTM A108)	SS 316/316 L Dual certified	SS 316/316 L Dual certified	
			CS (ASTM A108)	SS 316/316 L Dual certified	Tungsten Carbide Tip	
			Hastelloy® C-276*	Hastelloy® C-276*	Hastelloy® C-276*	
	For Preference Y	Duplex stainless steel UNS S31803/ S32205	Duplex stainless steel UNS S31803/ S32205	SS 316/316 L Dual certified	Duplex stainless steel UNS S31803/ S32205	
			Hastelloy® C-276*	SS 316/316 L Dual certified	Hastelloy® C-276*	
			Inconel 625	SS 316/316 L Dual certified	Inconel 625	
		Monel® 400**	Monel® 400**	Monel® 400**	Monel® 400**	
			SS 316/316 L Dual certified	SS 316/316 L Dual certified	Monel® 400**	
			Monel® 400**	SS 316/316 L Dual certified	Monel® 400**	

--A	*	*	*	*	*
--B	*	*	*	*	*
--C	*	*	*	*	*
--D	*	*	*	*	*
--E	*	*	*	*	*
--F	*	*	*	*	*
--G	*	*	*	*	*
--H	*	*	*	*	*
--J	*	*	*	*	*
--L	*	*	*	*	*
--M	*	*	*	*	*
--O	*	*	*	*	*
--P	*	*	*	*	*
--Q	*	*	*	*	*
--R	*	*	*	*	*
--S	*	*	*	*	*
--T	*	*	*	*	*
--U	*	*	*	*	*
--V	*	*	*	*	*
--W	*	*	*	*	*
--X	*	*	*	*	*
--Z	*	*	*	*	*

* Hastelloy® C-276 or UNS N10276 ** Monel® 400 or UNS N04400

Model Selection Guide

Table 2	Manifold bolts, tap and plug selection	Selection	Availability
a. Bolt material	No Bolts (Select ONLY for Block & Bleed OR for when ordered as integrated with SmartLine Transmitters) Carbon steel bolts SS 316 / 316 L Grade 660 (NACE A286) Bolts Monel® bolts	0 __ C __ S __ N __ M __	* * * * * c c c k k k k k k m m
b. Plug type	1/4" standard plug (OR NO PLUG IF MANIFOLD DOES NOT HAVE PLUG PORTS) (See note 2) 1/4" bleed plug (See note 3)	- S _ - B _ - 1 - 2	* * * * * * * * * * * * * * * * * * * *
c. Tap options	All taps standard "T" bar All taps anti-tamper (Anti-tamper key 50154757-502 shall be ordered separately.)		

Table 3	Brackets	Selection	Availability
Mounting Bracket for the Manifold (mounts directly on to the manifold)	None Mounting bracket Carbon Steel Mounting bracket SS	0 1 2	* * * * * * * e f * * * e f *

Table 4	Other Certifications & Options	Selection	Availability
Certifications & options (Note1)	Over-Pressure Leak Test Certificate (1.5X MAWP) NACE MR0175; MR0103; ISO15156 Process wetted parts only NACE MR0175; MR0103; ISO15156 Process wetted and non-wetted parts EN10204 Type 3.1 Material Traceability (default per heat code) Only one supplied per heat code (Offered by default) Certificate of Conformance (default per heat code) Only one supplied per heat code (Offered by default) PMI Certification (PMI Test for Manifold Body only) PMI Certification (PMI Test for Process wetted components) (Testing of individual components: Manifold Body, Bonnet, Stem, Trim) Cert Clean for O2 (Oxygen Cleaning and Certification)	TP FG F7 FX F3 P1 P2 OX	* * * * * g g g g g h h h h h * j j j j j

Table 5	Accessory Preference (may represent different choices of lead times, approvals and dimensions)*	Selection	Availability
Preference	Option X Option Z	1 2	a a a a a q q q q q

Table 6	Manufacturing Specials	Selection	Availability
Factory	Factory Identification	0000	* * * * *

* For additional information, contact your Honeywell Account Manager or Honeywell Authorized distributor

Restrictions				
Restriction Letter	Available only with		Not available with	
	Table	Selection	Table	Selection
a	1c	__A B,C,D,E,F,G,H, J,L,M		
c			1c	__G, H, J, L, M
d			1a	D __
e			1a	G __
			1c	__G, H, J, L, M
f			1a	N __
g			1c	__E, F, H, J, L, M
h			1c	__E, F, H, J, L, M
			2a	C, S, M __
j	1b	_ 1 _		
k			1c	__E, F
m	1c	__M		
n			1a	K, M, O __
b	Select only one option from this group			
q	1c	__O,P,Q,R,S,T,U,V,W,X, Z		

Notes:	
1	Customer needs to order same set of certification for integrated version while selecting the transmitter.
2	Plug material is the same as the manifold body material if the manifold has plug ports.
3	Vent/Bleed/Drain connection size is 1/4 Inch NPT F
4	Block and Bleed (Inline GP and AP) valves do not require gaskets, therefore they are not supplied.
5	6000 psi Standard Pressure Version PTFE Packing Maximum Pressure 413 bar (6,000 psi) at -30 to 100 deg C (212 deg F) Maximum Pressure 206 bar (3,000 psi) at 215 deg C (420 deg F)
	GRAPHITE Packing Maximum Pressure 413 bar (6,000 psi) at -30 to 100 deg C (212 deg F) Maximum Pressure 155 bar (2,250 psi) at 450 deg C (842 deg F)
6	For process temperature greater than 340 F (170 C) , grafoil packing needs to be used.
7	Flange thickness as per IEC 61518 Type B
8	Requires IEC 61518 Type B Futbol adapter 51156563-5XX. Please refer to the Accessories list to identify the matching material of the adapter to the manifold.
9	Select Preference X for Front vent or Preference Z for Bottom vent

Sales and Service

For application assistance, current specifications, ordering, pricing, and name of the nearest Authorized Distributor, contact one of the offices below.

ASIA PACIFIC

Honeywell Process Solutions,
Phone: + 800 12026455 or
+44 (0) 1202645583
(TAC) hfs-tac-support@honeywell.com

Australia

Honeywell Limited
Phone: +(61) 7-3846 1255
FAX: +(61) 7-3840 6481
Toll Free 1300-36-39-36
Toll Free Fax:
1300-36-04-70

China – PRC - Shanghai

Honeywell China Inc.
Phone: (86-21) 5257-4568
Fax: (86-21) 6237-2826

Singapore

Honeywell Pte Ltd.
Phone: +(65) 6580 3278
Fax: +(65) 6445-3033

South Korea

Honeywell Korea Co Ltd
Phone: +(822) 799 6114
Fax: +(822) 792 9015

EMEA

Honeywell Process Solutions,
Phone: + 800 12026455 or
+44 (0) 1202645583

Email: (Sales)

FP-Sales-Apps@Honeywell.com

or

(TAC)

hfs-tac-support@honeywell.com

AMERICAS

Honeywell Process Solutions,
Phone: (TAC) (800) 423-9883
or (215) 641-3610
(Sales) 1-800-343-0228

Email: (Sales)

FP-Sales-Apps@Honeywell.com

or

(TAC)

hfs-tac-support@honeywell.com

For more information

To learn more about SmartLine Transmitters,
visit www.process.honeywell.com
Or contact your Honeywell Account Manager

Process Solutions

Honeywell
1250 W Sam Houston Pkwy S
Houston, USA, TX 77042

Honeywell Control Systems Ltd
Honeywell House, Skimped Hill Lane
Bracknell, England, RG12 1EB

Shanghai City Centre, 100 Jungi Road
Shanghai, China 20061

www.process.honeywell.com



34-ST-03-149
December 2023

©2023 Honeywell International Inc.