

STA700 SmartLine Absolute Pressure Specification 34-ST-03-100, December 2025



Introduction

Part of the SmartLine® family of products, the STA700 and STA70L are suitable for monitoring, control and data acquisition featuring piezoresistive sensor technology combining pressure sensing with on chip temperature compensation capabilities providing high accuracy, stability and performance over a wide range of application pressures and temperatures. The SmartLine family is also fully tested and compliant with Experion® PKS providing the highest level of compatibility, assurance and integration capabilities. SmartLine easily meets the most demanding application needs for pressure measurement applications.

Best in Class Features:

- Accuracies up to 0.055% of span standard & 0.04% of span optional.
- Stability up to 0.02% of URL per year for 10 years.
- Automatic temperature compensation.
- Rangeability up to 100:1.
- Response times as fast as 100ms.
- Multiple local display capabilities.
- External zero, span, & configuration capability.
- Polarity insensitive electrical connections.
- Comprehensive on-board diagnostic capabilities.
- Integral Dual Seal design for safety based on ANSI/NFPA 70-202 and ANSI/ISA 12.27.0.
- Full compliance to SIL 2/3 requirements.
- Modular design characteristics.
- Available with additional 4-year warranty.
- Supports NAMUR NE-107 Extended Diagnostics (HART).



Figure 1 – STA700 Absolute Pressure Transmitters feature field-proven piezoresistive sensor technology

Communications/Output Options:

- Honeywell Digitally Enhanced (DE)
- HART® (version 7.0)

All transmitters are available with the above listed communications protocols.

Span & Range Limits:

Model	URL mmHgA (mbarA)	LRL mmHgA (mbarA)	Min Span mmHgA (mbarA)
STA722/72L	780 (1040)	0 (0)	50 (66.7)
Model	psia (barA)	psi (barA)	psi (barA)
STA740/74L	500 (35)	0 (0)	5 (0.35)

Description

The SmartLine family pressure transmitters are designed around a high performance piezo-resistive sensor. This one sensor actually integrates multiple sensors linking process pressure measurement with on-board static pressure (DP Models) and temperature compensation measurements. This level of performance allows the ST 700 to replace most competitive transmitters available today.

Unique Indication/Display Option

The ST 700 modular design accommodates a standard alphanumeric LCD display or a unique advanced graphics LCD display with many unparalleled features.

Standard LCD Display Features

- Modular (may be added or removed in the field).
- Supports HART protocol variant.
- 0, 90, 180, and 270 degree position adjustments.
- Four configurable screens.
- Standard and custom measurement units available.
- Display calculated flow (square root) value in addition to analog output signal.
- 2 Lines 6 digits PV (9.95H x 4.20W mm) 8 Characters.
- Write protect Indication.
- Built-in Basic Device Configuration through Internal or External Buttons – Range/Engineering Unit/Loop Test /Loop Calibration/Zero /Span Setting.
- Multiple language capabilities (EN, RU, and UK).

Advanced Graphics LCD Display Features

- Modular (may be added or removed in the field).
- 0, 90, 180, & 270-degree position adjustments.
- Standard and custom measurement units available.
- Up to eight display screens with 3 formats are possible.
- Large PV with Bar Graph or PV with Trend Graph.
- Configurable screen rotation timing (1 to 30 sec).
- Display calculated flow (square root) value in addition to analog output signal.
- Unique “Health Watch” indication provides instant visibility of diagnostics.
- Multiple language capability (EN, DE, FR, IT, ES, RU, UK, TR, CN, and JP).

Diagnostics

SmartLine transmitters all offer digitally accessible diagnostics which aid in providing advanced warning of possible failure events minimizing unplanned shutdowns, providing lower overall operational costs.

System Integration

- SmartLine communications protocols all meet the most current published standards for HART/DE.
- Integration with Honeywell’s Experion PKS offers the following unique advantages.
 - Tamper reporting
 - FDM Plant Area Views with Health summaries
 - All ST 700 units are Experion tested to provide the highest level of compatibility assurance.

Configuration Tools

Integral Two Button Configuration Option

Suitable for all electrical and environmental requirements, SmartLine offer the ability to configure the transmitter and display via three externally accessible buttons when either display option is selected. Zero/span capabilities are also optionally available via these buttons with or without selection of a display option.

Handheld Configuration

SmartLine transmitters feature two-way communication and configuration capability between the operator and the transmitter. All Honeywell transmitters are designed and tested for compliance with the offered communication protocols and are designed to operate with any standards compliant handheld configuration device, such as the Honeywell Versatilis Configurator.

Personal Computer Configuration

On a personal computer or laptop, Honeywell Field Device Manager (FDM) Software and FDM Express can be used for managing HART & Fieldbus device configurations.

Modular Design

To help contain maintenance & inventory costs, all ST 700 transmitters are modular in design supporting the user’s ability to replace meter bodies, add indicators or change electronic modules without affecting overall performance or approval body certifications. Each meter body is uniquely characterized to provide in-tolerance performance over a wide range of application variations in temperature and pressure and due to the Honeywell advanced interface, electronic modules may be swapped with any electronics module without losing in-tolerance performance characteristics.

Modular Features

- Meter body replacement
- Exchange/replace electronics/comms modules*
- Add or remove integral indicator*
- Add or remove lightning protection (terminal connection)*

* Field replaceable in all electrical environments (including IS) except flameproof without violating agency approvals.

With no performance effects, Honeywell’s unique modularity results in **lower inventory needs and lower overall operating costs**.

Performance Specifications

Reference Accuracy: (conformance to +/-3 Sigma)

Table 1

Model	URL	LRL	Min Span	Maximum Turndown Ratio	Stability (% URL/Year for 10 years)	Reference Accuracy ^{1,2} (% Span) Standard / optional
STA722	780 mmHgA (1040 mbarA)	0.0 mmHgA (0.0 mbarA)	50 mmHgA (66.6 mbarA)	15.6:1	0.020	0.055 / 0.040
STA740	500 psia (35 barA)	0.0 mmHgA (0.0 mbarA)	5 psia (0.35 barA)	100:1		
STA72L	780 mmHgA (1040 mbarA)	0.0 mmHgA (0.0 mbarA)	50 mmHgA (66.6 mbarA)	15.6:1		
STA74L	500 psia (35 barA)	0.0 mmHgA (0.0 mbarA)	5 psia (0.35 barA)	100:1		

Zero and span may be set anywhere within the listed (URL/LRL) range limits

Accuracy at Specified Span and Temperature: (Conformance to +/-3 Sigma)

Table 2

	Model	URL	Reference Turndown	Accuracy ^{1,2} (% of Span)			Combined Zero & Span temperature Effect (% Span/28°C (50°F))	
				A	B	C (see URL units)	D	E
Standard Accuracy	STA722	780 mmHgA(1040 mbarA)	8.7:1	0.005	0.050	90 (120)	0.065	0.045
	STA740	500 psia (35 barA)	25:1			20 (1.4)	0.050	0.010
	STA72L	780 mmHgA (1040 mbarA)	5.6:1			140 (186.7)	0.065	0.100
	STA74L	500 psia (35 barA)	25:1			20 (1.4)	0.050	0.015
High Accuracy Option	STA722	780 mmHgA (1040 mbarA)	8.7:1	0.005	0.035	90 (120)	0.065	0.045
	STA740	500 psia (35 barA)	25:1			20 (1.4)	0.050	0.010
	STA72L	780 mmHgA (1040 mbarA)	5.6:1			140 (186.7)	0.065	0.100
	STA74L	500 psia (35 barA)	25:1			20 (1.4)	0.050	0.015
Turn Down Effect							Temp Effect	
$\pm [A + B] \quad \text{if } Span \geq C$ $\pm \left[A + B \left(\frac{C}{Span} \right) \right] \quad \text{if } Span < C$							$\pm \left[D + E \left(\frac{URL}{Span} \right) \right]$	

Total Performance (% of Span):

$$\text{Total Performance Calculation: } = \pm \sqrt{(\text{Accuracy})^2 + (\text{Temperature Effect})^2}$$

Total Performance Examples (for comparison): standard accuracy @ 5:1 Turndown, +/-50°F (28°C) shift

STA722 @ 156 mmHgA: 0.295% of span

STA72L @ 156 mmHgA: 0.567% of span

STA740 @ 100 psia: 0.114% of span

STA74L @ 100 psia: 0.137% of span

Typical Calibration Frequency:

Calibration verification is recommended every two (2) years

Notes:

1. Terminal Based Accuracy - Includes combined effects of linearity, hysteresis, and repeatability. Analog output adds 0.005% of span.
2. For zero based spans and reference conditions of: 25 °C (77°F), 10 to 55% RH, and 316 Stainless Steel barrier diaphragm.

Operating Conditions – All Models

Parameter	Reference Condition		Rated Condition		Operative Limits		Transportation and Storage							
	°C	°F	°C	°F	°C	°F	°C	°F						
Ambient Temperature¹	25±1	77±2	-40 to 85	-40 to 185	-40 to 85	-40 to 185	-55 to 120	-67 to 248						
Meter Body Temperature²														
STA722/STA72L	25±1	77±2	See Figure 1		See Figure 1		-55 to 125	-67 to 257						
STA740/74L	25±1	77±2	-40 to 110	-40 to 230	-40 to 125	-40 to 257	-55 to 125	-67 to 257						
Humidity %RH	10 to 55		0 to 100		0 to 100		0 to 100							
Vacuum Region - Minimum Pressure STA722/72L/740/74L	See Figure 2. Operate within specifications above 25 mmHgA (33 mbarA). Short term ³ exposure to full vacuum will not result in damage.													
Supply Voltage Load Resistance	HART: 10.8 to 42.4 VDC at terminals (IS versions limited to 30 VDC), 0 to 1,440 ohms DE: 15 to 49.3VDC at terminals (IS versions limited to 30VDC), 0 to 1,200 ohms (as shown in Figure 3)													
Maximum Allowable Working Pressure (MAWP)⁴	STA722/72L = 780 mmHgA, (1,040 mbarA) STA740/74L = 500 psia (35 barA)													
Over Pressure	1.5 x MAWP of respective model													
No-Burst Pressure	<table border="1"> <thead> <tr> <th>Transmitter MAWP (psi)</th> <th>Minimum 'no-burst pressure'</th> </tr> </thead> <tbody> <tr> <td>MAWP ≤ 2,000 psi</td> <td>3x MAWP</td> </tr> <tr> <td>MAWP > 2,000 psi</td> <td>2.5x MAWP + 1000 psi</td> </tr> </tbody> </table>								Transmitter MAWP (psi)	Minimum 'no-burst pressure'	MAWP ≤ 2,000 psi	3x MAWP	MAWP > 2,000 psi	2.5x MAWP + 1000 psi
Transmitter MAWP (psi)	Minimum 'no-burst pressure'													
MAWP ≤ 2,000 psi	3x MAWP													
MAWP > 2,000 psi	2.5x MAWP + 1000 psi													

¹ LCD display ambient temperature: -30°C to +70°C. LCD display storage temperature: -30°C to +80°C. The display will be slower and may become unreadable as the ambient temperature drops below -20°C to -30°C. It will return to normal functionality once the ambient temperature rises above -20°C.

² Silicone 704 minimum temperature rating is 0°C (32°F). CTFE minimum temperature rating is -40°C (-40°F).

³ Short term equals 2 hours at 70°C (158°F).

⁴ Consult factory for MAWP of ST 700 transmitters with CRN approval.

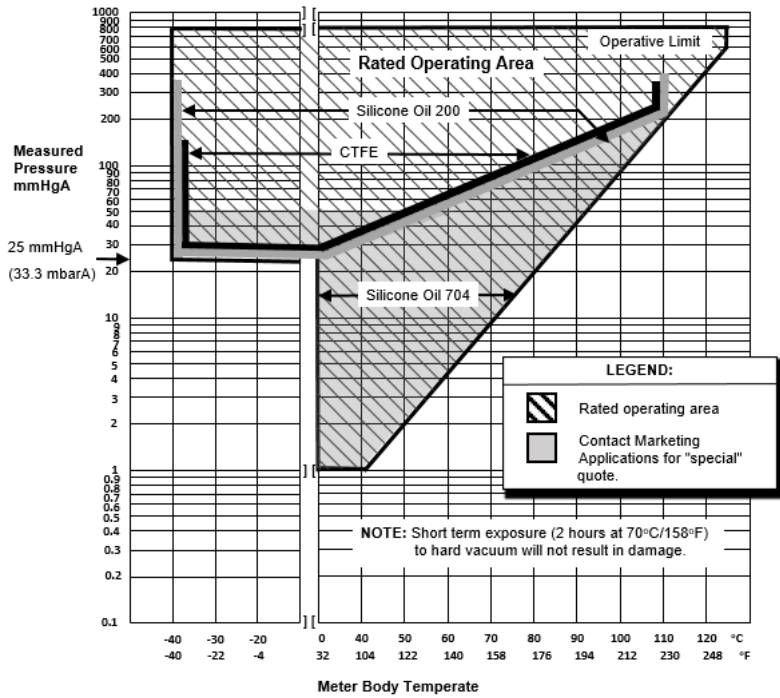

Figure 2 - Measured pressure versus meter body temperature chart for STA722, 72L

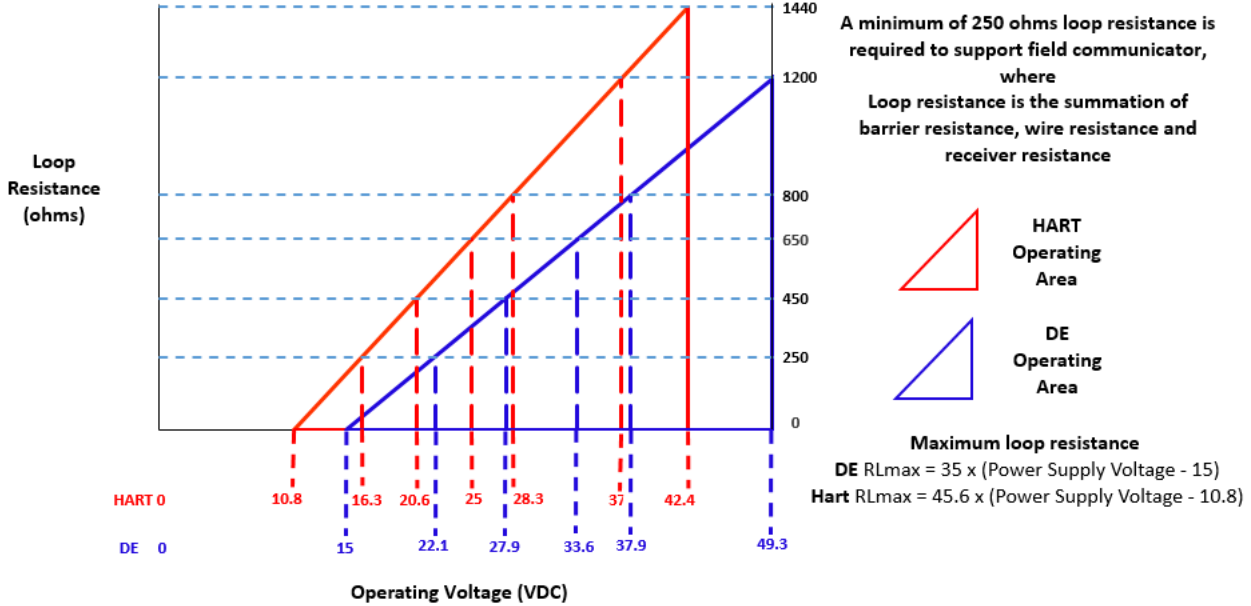

Figure 3 - Supply voltage and loop resistance chart & calculations

Performance Under Rated Conditions – All Models

Parameter	Description									
Analog Output Digital Communications:	Two-wire, 4 to 20 mA (HART & DE Transmitters only) Honeywell DE, HART protocol All transmitters, irrespective of protocol, have polarity insensitive connection.									
HART & DE Output Failure Modes (NAMUR for DE Units requires selecting display and configuration buttons or factory configuration)	<table border="0"> <thead> <tr> <th></th> <th>Honeywell Standard</th> <th>NAMUR NE 43 Compliance</th> </tr> </thead> <tbody> <tr> <td>Normal Limits:</td> <td>3.8 – 20.8 mA</td> <td>3.8 – 20.5 mA</td> </tr> <tr> <td>Failure Mode:</td> <td>≤ 3.6 mA and ≥ 21.0 mA</td> <td>≤ 3.6 mA and ≥ 21.0 mA</td> </tr> </tbody> </table>		Honeywell Standard	NAMUR NE 43 Compliance	Normal Limits:	3.8 – 20.8 mA	3.8 – 20.5 mA	Failure Mode:	≤ 3.6 mA and ≥ 21.0 mA	≤ 3.6 mA and ≥ 21.0 mA
	Honeywell Standard	NAMUR NE 43 Compliance								
Normal Limits:	3.8 – 20.8 mA	3.8 – 20.5 mA								
Failure Mode:	≤ 3.6 mA and ≥ 21.0 mA	≤ 3.6 mA and ≥ 21.0 mA								
Supply Voltage Effect	0.005% of span per volt.									
Transmitter Turn on Time (includes power up & test algorithms)	HART or DE: 2.5 seconds									
Response Time (delay + time constant)	<u>DE/HART Protocol</u> 100ms									
Damping Time Constant	HART: Adjustable from 0 to 32 seconds in 0.1 increments. Default Value: 0.5 seconds DE: Discrete values 0, .16, .32, .48, 1, 2, 4, 8, 16, 32 seconds. Default Value: 0.48 seconds									
Vibration Effect	Less than +/- 0.1% of URL w/o damping Per IEC60770-1 field or pipeline, high vibration level (10-2000Hz: 0.21 displacement/3g max acceleration)									
Electromagnetic Compatibility	Meets IEC61326-3-1									
Lightning Protection Option	Leakage Current: 10uA max @ 42.4VDC 93C Impulse rating: 8/20us 5000A (>10 strikes) 10000A (1 strike min.) 10/1000us 200A (> 300 strikes)									

Materials Specifications (see model selection guide for availability/restrictions with various models)

Parameter	Description
Barrier Diaphragms Material	STA700: 316L SS, Hastelloy® C-276 ² , Monel® 400 ³ , Tantalum STA70L: 316L SS, Hastelloy C-276
Process Head Material	STA700: Carbon Steel (Zinc Plated) ⁵ , 316 SS ⁴ , Hastelloy® C-276 ⁶ , Monel® 400 ⁷ STG70L: 316L SS, Hastelloy® C-276 ⁶
Vent/Drain Valves & Plugs ¹	STA700: 316 SS ⁴ , Hastelloy C-276 ² , Monel 400 ⁷ STA70L: N/A
Head Gaskets	STA700: Glass-filled PTFE standard. Viton® and graphite are optional. STA70L: N/A
Meter Body Bolting	STA700: Carbon Steel (Zinc plated) standard. Options include 316 SS, NACE A286 SS bolts and nuts or NACE A286 SS bolts and 304 SS nuts STA70L: N/A
Mounting Bracket	Carbon Steel (Zinc-plated) or 304 Stainless Steel or 316 Stainless Steel. See Figures 4 & 5
Fill Fluid	Silicone 200, CTFE (Chlorotrifluoroethylene) or Silicone 704
Electronic Housing	Pure Polyester Powder Coated Low Copper (<0.4%) – Aluminum. Meets Type 4X / IP66 / IP67. All stainless-steel housing is optional. Cover O ring material: Silicone.
Process Connections	STA700: ½ -inch NPT (female), DIN 19213 (standard) STA70L: ½ -inch NPT (female), ½ -inch NPT male, 9/16 Aminco, DIN19213. G½ -B Male Thread
Wiring	Accepts up to 16 AWG (1.5 mm diameter).
Dimensions	See Figure 4 & 5
Net Weight	STA700: 8.3 pounds (3.8 Kg). STA70L: 3.6 pounds (1.6 Kg) with Aluminum Housing

¹ Vent/Drains are sealed with Teflon®

² Hastelloy® C-276 or UNS N10276.

³ Monel® 400 or UNS N04400.

⁴ Supplied as 316 SS or as Grade CF8M, the casting equivalent of 316 SS.

⁵ Carbon Steel heads are zinc-plated and not recommended for water service due to hydrogen migration. For that service, use 316 stainless steel wetted Process Heads.

⁶ Hastelloy® C-276 or UNS N10276. Supplied as indicated or as Grade CW12MW, the casting equivalent of Hastelloy® C-276.

⁷ Monel® 400 or UNS N04400. Supplied as indicated or as Grade M30C, the casting equivalent of Monel® 400.

Communications Protocol & Diagnostics

HART Protocol

Version: HART 7

Honeywell Digitally Enhanced (DE)

DE is a Honeywell proprietary protocol that provides digital communications between Honeywell DE enabled field devices and hosts.

Standard Diagnostics

ST 700 top level diagnostics are reported as either critical or non-critical and are readable via the DD/DTM/FDI tools or integral display. All critical diagnostics will appear on the Advanced and Standard integral displays, and some non-critical diagnostics will also appear on the Advanced integral display. Some of the diagnostics are listed below.

Critical Diagnostics

- Electronics Module Fault.
- Meter body Memory Corruption.
- Config Data Corruption.
- Electronics Module Diagnostics Failure.
- Meter body Critical Failure.
- Sensor Communication Timeout.











Non-Critical Diagnostics

- Electronics Module Fault.
- Display Failure.
- Electronics Module Comm Failure.
- Meter body Excess Correct.
- Sensor Over Temperature.
- Fixed Current Mode.
- PV Out of Range.
- No DAC Compensation.
- Tamper Attempt Alarm.

Refer to the product user manual for comprehensive list of diagnostics and details.

Hazardous Area Certifications

MSG CODE	AGENCY	TYPE OF PROTECTION	COMM. OPTION	ELECTRICAL PARAMETERS	AMBIENT TEMP (Ta)
A	FM Approvals™ USA	Explosionproof: Class I, Division 1, Groups A, B, C, D; Dust Ignition Proof: Class II, III, Division 1, Groups E, F, G; T6..T5 Class I, Zone 0/1, AEx db IIC T6..T5 Ga/Gb Class II, Zone 21, AEx tb IIIC T95° Db	All	Note 1	T5: -50 °C to 85°C T6: -50 °C to 65°C
		Intrinsically Safe: Class I, II, III, Division 1, Groups A, B, C, D, E, F, G: T4 Class I, Zone 0, AEx ia IIC T4 Ga FISCO Field Device (Only for FF Option) Ex ia IIC T4 Ga; Ex ic IIC T4 Gc	4-20 mA / DE/ HART	Note 2a	-50 °C to 70°C
		Nonincendive: Class I, Division 2, Groups A, B, C, D locations, T4 Class I, Zone 2, AEx nA IIC T4 Gc	Foundation Fieldbus	Note 2b	-50 °C to 70°C
		Nonincendive: Class I, Division 2, Groups A, B, C, D locations, T4 Class I, Zone 2, AEx nA IIC T4 Gc	4-20 mA / DE/ HART/ Foundation Fieldbus	Note 1	-50 °C to 85°C
		Enclosure: Type 4X/ IP66/ IP67	All	All	-
		STANDARDS: FM Class 3600:2011; FM Class 3610: 2010; FM Class 3611: 2004; FM Class 3615: 2006; FM Class 3616: 2011; FM Class 3810: 2005; ANSI/ISA 60079-0: 2013; ANSI/UL 60079-1: 2015; ANSI/UL 60079-11: 2014; ANSI/ISA 60079-15: 2012; ANSI/UL 60079-26: 2017; ANSI/UL 60079-31: 2015; ANSI/NEMA 250: 2003; ANSI/ IEC 60529: 2004			
B	Canadian Standards Association (CSA) USA and Canada	Explosion Proof: Class I, Division 1, Groups A, B, C, D; Class II, Division 1, Groups E, F, G; Class III, Division 1, T6..T5 Class I Zone 1 AEx db IIC T6..T5 Ga/Gb Ex db IIC T6..T5 Ga/Gb Zone 22 AEx tb IIIC T95° Db Ex tb IIIC T95° Db	All	Note 1	T5: -50°C TO 85°C T6: -50°C TO 65°C
		Intrinsically Safe: Class I, II, III, Division 1, Groups A, B, C, D; Class II, Division 1, Groups E, F, G; Class III, Division 1, T4 Class I Zone 0, AEx ia IIC T4 Ga Class I Zone 2, AEx ic IIC T4 Gc Ex ia IIC T4 Ga Ex ic IIC T4 Gc FISCO Field Device (Only for FF Option) Ex ia IIC T4 Ga; Ex ic IIC T4 Gc	4-20 mA / DE/ HART	Note 2	-50°C TO 70°C
		Nonincendive: Class I, Division 2, Groups A, B, C, D; Class II, Division 2, Groups F, G; Class III, Division 2, T4 Class I Zone 2 AEx nA IIC T4 Gc Ex nA IIC T4 Gc	Foundation Fieldbus	Note 2	-50°C TO 70°C
		Nonincendive: Class I, Division 2, Groups A, B, C, D; Class II, Division 2, Groups F, G; Class III, Division 2, T4 Class I Zone 2 AEx nA IIC T4 Gc Ex nA IIC T4 Gc	4-20 mA / DE/ HART/ Foundation Fieldbus	Note 1	-50°C to 85°C
		Enclosure: Type 4X/ IP66/ IP67	All	All	-

MSG CODE	AGENCY	TYPE OF PROTECTION	COMM. OPTION	ELECTRICAL PARAMETERS	AMBIENT TEMP (Ta)
		STANDARDS: CSA C22.2 No. 0-10; CSA C22.2 No. 94-M91; CSA C22.2 No. 25-1966; CSA C22.2 No. 30-M1986; CSA C22.2 No. 142-M1987; CSA C22.2 No. 157-92; CSA C22.2 No. 213-M1987; CSA-C22.2 No. 60529:05; CSA-C22.2 No. 60079-0:11; CSA-C22.2 No. 60079-1:11; CSA-C22.2 No. 60079-11:11; CSA-C22.2 No. 60079-15:12; CSA-C22.2 No. 60079-31:12; ISA 12.12.01-2010; ISA 60079-0: 2009; ISA 60079-11: 2011; ISA 60079-15: 2009; ISA 60079-26: 2008; ISA-60079-27:2007 (12.02.04)-2006 (R2011); UL 913 Ed. 6; UL 916:1998; ANSI/ISA-12.27.01-2011			
C	ATEX	Flameproof: SIRA 12ATEX2233X  II 1/2 G Ex db IIC T6..T5 Ga/Gb II 2 D Ex tb IIIC T95°C...T120°C Db	All	Note 1	T5: -50°C TO 85°C T6: -50°C TO 65°C
		Intrinsically Safe: SIRA 12ATEX2233X  II 1 G Ex ia IIC T4 Ga II 2 D Ex ia IIIC T125°C Db FISCO Field Device (Only for FF Option) II 1 G Ex ia IIC T4 Ga	4-20 mA / DE/ HART	Note 2	-50°C TO 70°C
		Zone 2, Increase Safety: SIRA 12ATEX4234X  II 3 G Ex ec IIC T4 Gc	Foundation Fieldbus	Note 2	-50°C TO 70°C
		Zone 2, Increase Safety: SIRA 12ATEX4234X  II 3 G Ex ec IIC T4 Gc	4-20 mA / DE/ HART/ Foundation Fieldbus	Note 1	-50°C TO 85°C
		Zone 2, Intrinsically Safe: SIRA 12ATEX4234X  II 3 G Ex ic IIC T4 Gc FISCO Field Device (Only for FF Option) II 3 G Ex ic IIC T4 Gc	4-20 mA / DE/ HART/ Foundation Fieldbus	Note 2	-50°C TO 85°C
		Enclosure: IP66/ IP67	All	All	-
	STANDARDS: EN IEC 60079-0: 2018; EN 60079-1: 2014; EN 60079-7: 2015+A1:2018; EN 60079-11: 2012; EN 60079-26: 2015; EN 60079-31: 2014				
	UKEx	Flameproof: CSAE 22UKEX1021X  II 1/2 G Ex db IIC T6..T5 Ga/Gb II 2 D Ex tb IIIC T95°C...T120°C Db	All	Note 1	T5: -50°C TO 85°C T6: -50°C TO 65°C
		Intrinsically Safe: CSAE 22UKEX1021X  II 1 G Ex ia IIC T4 Ga II 2 D Ex ia IIIC T125°C Db FISCO Field Device (Only for FF Option) II 1 G Ex ia IIC T4 Ga	4-20 mA / DE/ HART	Note 2	-50°C TO 70°C
		Zone 2, Increase Safety: CSAE 22UKEX1008X  II 3 G Ex ec IIC T4 Gc	Foundation Fieldbus	Note 2	-50°C TO 70°C
		Zone 2, Increase Safety: CSAE 22UKEX1008X  II 3 G Ex ec IIC T4 Gc	4-20 mA / DE/ HART/ Foundation Fieldbus	Note 1	-50°C TO 85°C
Zone 2, Intrinsically Safe: CSAE 22UKEX1008X  II 3 G Ex ic IIC T4 Gc FISCO Field Device (Only for FF Option) II 3 G Ex ic IIC T4 Gc	4-20 mA / DE/ HART/ Foundation Fieldbus	Note 2	-50°C TO 85°C		

MSG CODE	AGENCY	TYPE OF PROTECTION	COMM. OPTION	ELECTRICAL PARAMETERS	AMBIENT TEMP (Ta)
		Enclosure: IP66/ IP67	All	All	-
		STANDARDS: EN IEC 60079-0: 2018, EN 60079-1: 2014; EN 60079-7: 2015+A1: 2018; EN 60079-11: 2012; EN 60079-26: 2015; EN 60079-31: 2014			
D	IECEX World	Flameproof: IECEx SIR 12.0100X Ex db IIC T6..T5 Ga/Gb Ex tb IIIC T95°C...T120°C Db	All	Note 1	T5: -50°C TO 85°C T6: -50°C TO 65°C
		Intrinsically Safe: IECEx SIR 12.0100X Ex ia IIC T4 Ga Ex ia IIIC T125°C Db FISCO Field Device (Only for FF Option) Ex ia IIC T4 Ga; Ex ic IIC T4 Gc	4-20 mA / DE/ HART	Note 2	-50°C TO 70°C
			Foundation Fieldbus	Note 2	-50°C TO 70°C
		Zone 2, Increase Safety: IECEx SIR 12.0100X Ex ec IIC T4 Gc	4-20 mA / DE/ HART/ Foundation Fieldbus	Note 1	-50°C TO 85°C
		Zone 2, Intrinsically Safe: IECEx SIR 12.0100X Ex ic IIC T4 Gc FISCO Field Device (Only for FF Option) Ex ic IIC T4 Gc	4-20 mA / DE/ HART/ Foundation Fieldbus	Note 2	-50°C TO 85°C
		Enclosure: IP66/ IP67	All	All	-
		STANDARDS: IEC 60079-0: 2017; IEC 60079-1: 2014; IEC 60079-7: 2017; IEC 60079-11: 2011; IEC 60079-26: 2014; IEC 60079-31: 2013			
E	SAEx South Africa	Flameproof : Ex d IIC T6...T5 Ga/Gb Ex tb IIIC T95°C...T120°C Db	All	Note 1	T5: -50°C TO 85°C T6: -50°C TO 65°C
		Intrinsically Safe: Ex ia IIC Ga T4 FISCO Field Device (Only for FF Option) Ex ia IIC T4 Ga; Ex ic IIC T4 Gc	4-20 mA / DE/ HART	Note 2	-50°C TO 70°C
			Foundation Fieldbus	Note 2	-50°C TO 70°C
		Zone 2, Increase Safety: II 3 G Ex ec IIC T4 Gc	4-20 mA / DE/ HART/ Foundation Fieldbus	Note 1	-50°C TO 85°C
		Zone 2, Intrinsically Safe: Ex ic IIC T4 Gc FISCO Field Device (Only for FF Option) Ex ic IIC T4 Gc	4-20 mA / DE/ HART/ Foundation Fieldbus	Note 2	-50°C TO 85°C
Enclosure: IP66/ IP67	All	All	-		

MSG CODE	AGENCY	TYPE OF PROTECTION	COMM. OPTION	ELECTRICAL PARAMETERS	AMBIENT TEMP (Ta)
F	INMETRO Brazil	Flameproof: Ex db IIC T6..T5 Ga/Gb Ex tb IIIC T95°C...T120°C Db	All	Note 1	T5: -50°C TO 85°C T6: -50°C TO 65°C
		Intrinsically Safe: Ex ia IIC T4 Ga	4-20 mA / DE/ HART	Note 2a	-50°C TO 70°C
		FISCO Field Device (Only for FF Option) Ex ia IIC T4 Ga; Ex ic IIC T4 Gc	Foundation Fieldbus	Note 2b	-50°C TO 70°C
		Zone 2, Increase Safety: II 3 G Ex ec IIC T4 Gc	4-20 mA / DE/ HART/ Foundation Fieldbus	Note 1	-50°C TO 85°C
		Zone 2, Intrinsically Safe: Ex ic IIC T4 Gc FISCO Field Device (Only for FF Option) Ex ic IIC T4 Gc	4-20 mA / DE/ HART/ Foundation Fieldbus	Note 2	-50°C TO 85°C
		Enclosure : IP 66/67	All	All	-
G	NEPSI CHINA	Flameproof: Ex db IIC T6..T5 Ga/Gb Ex tb IIIC T 95°C Db	All	Note 1	T5: -50°C TO 85°C T6: -50°C TO 65°C
		Intrinsically Safe: Ex ia IIC T4 Ga	4-20 mA / DE/ HART	Note 2	-50°C TO 70°C
		FISCO Field Device (Only for FF Option) Ex ia IIC T4 Ga; Ex ic IIC T4 Gc	Foundation Fieldbus	Note 2	-50°C TO 70°C
		Zone 2, Increase Safety: II 3 G Ex ec IIC T4 Gc	4-20 mA / DE/ HART/ Foundation Fieldbus	Note 1	-50°C TO 85°C
		Zone 2, Intrinsically Safe: Ex ic IIC T4 Gc FISCO Field Device (Only for FF Option) Ex ic IIC T4 Gc	4-20 mA / DE/ HART/ Foundation Fieldbus	Note 2	-50°C TO 85°C
		Enclosure : IP 66/67	All	All	-
H	KOSHA Korea	Flameproof : Ex d IIC T4, T5, T6 Ex tD A21 IP66/IP67 T95°C...T120 °C	All	Note 1	T4: -50°C TO 85°C T5: -50°C TO 85°C T6: -50°C TO 65°C
		Intrinsically Safe: Ex ia IIC T4	4-20 mA / DE/ HART	Note 2	Ta= -50 °C to 70°C
			Foundation Fieldbus	Note 2	Ta= -50 °C to 70°C
		Enclosure: IP66/ IP67	All	All	-
I	EAC Russia, Belarus and Kazakhstan	Flameproof: Ga/Gb Ex d IIC T6..T5 Ex tb IIIC Db T 85°C	All	Note 1	T5: -50°C TO 85°C T6: -50°C TO 65°C
		Intrinsically Safe: Ga Ex ia IIC T4 X	4-20 mA / DE/ HART	Note 2	-50°C TO 70°C

		FISCO Field Device (Only for FF Option) Ga Ex ia IIC T4 X	Foundation Fieldbus	Note 2	-50°C TO 70°C
		Zone 2, Non Sparking: 2 Ex nA IIC T4 Gc X	4-20 mA / DE/ HART/ Foundation Fieldbus	Note 1	-50°C TO 85°C
		Zone 2, Intrinsically Safe: Ga Ex ic IIC T4 X FISCO Field Device (Only for FF Option) 2 Ex ic IIC T4 Gc X	4-20 mA / DE/ HART/ Foundation Fieldbus	Note 2	-50°C TO 85°C
		Enclosure : IP 66/67	All	All	
J	CCoE INDIA	Flameproof: Ex d IIC T6..T5 Ga/Gb	All	Note 1	T5: -50°C TO 85°C T6: -50°C TO 65°C
		Intrinsically Safe: Ex ia IIC T4 Ga FISCO Field Device (Only for FF Option) Ex ia IIC T4 Ga; Ex ic IIC T4 Gc	4-20 mA / DE/ HART	Note 2	-50°C TO 70°C
			Foundation Fieldbus	Note 2	-50°C TO 70°C
		Non Sparking Ex nA IIC T4 Gc	4-20 mA / DE/ HART/ Foundation Fieldbus	Note 1	-50°C TO 85°C
		Enclosure: IP66/ IP67	All	All	-
K	UATR UKRAINE	Flameproof: II 1/2 G Ex db IIC T6..T5 Ga/Gb II 2 D Ex tb IIIC T95°C...T120°C Db	All	Note 1	T5: -50°C TO 85°C T6: -50°C TO 65°C
		Intrinsically Safe: II 1 G Ex ia IIC T4 Ga FISCO Field Device (Only for FF Option) II 1 G Ex ia IIC T4 Ga	4-20 mA / DE/ HART	Note 2	-50°C TO 70°C
			Foundation Fieldbus	Note 2	-50°C TO 70°C
		Enclosure: IP66/ IP67	All	All	-

Other Certification Options

Materials

- NACE MRO175, MRO103, ISO15156
- Mounting & Dimensional Drawings)

Mounting Configurations (Dual head design)

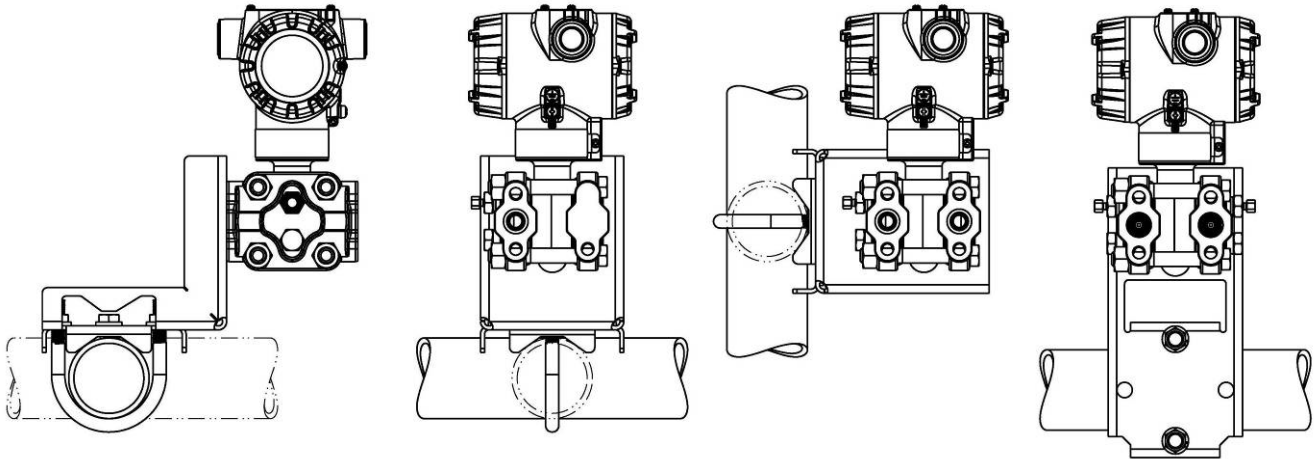

Reference Dimensions: $\frac{\text{millimeters}}{\text{inches}}$

Dimensions (Dual head design)

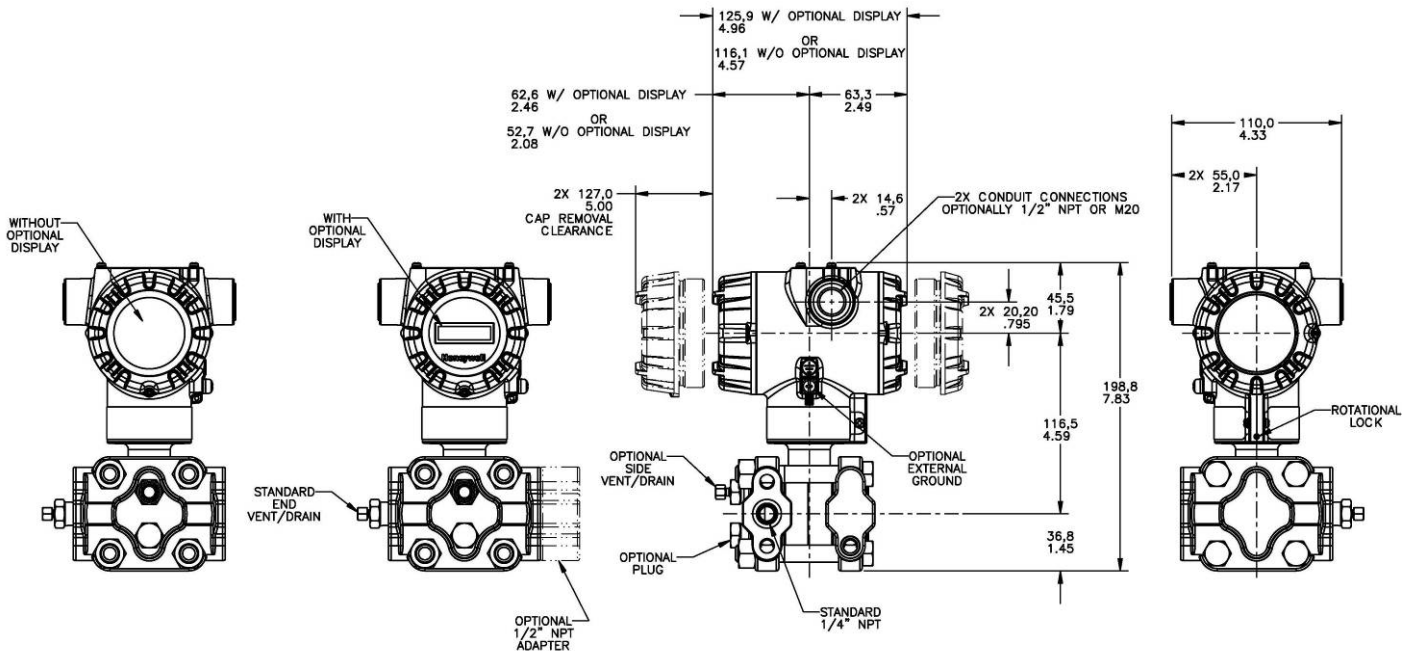
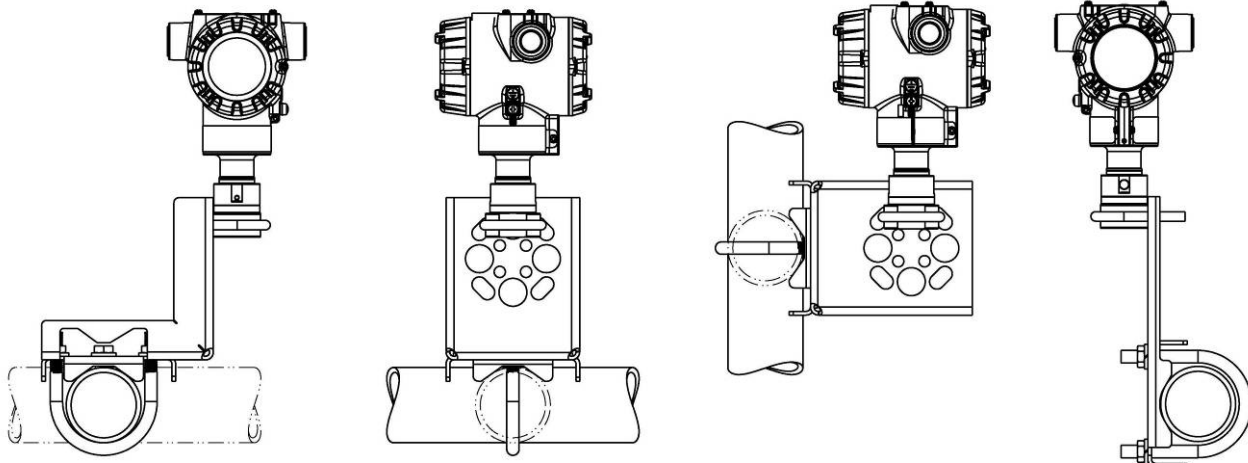

Figure 4 – Typical mounting dimensions of STA722 & STA740 for reference

Mounting Configurations (Inline Designs)



Reference Dimensions: $\frac{\text{millimeters}}{\text{inches}}$

Dimension (Inline Design)

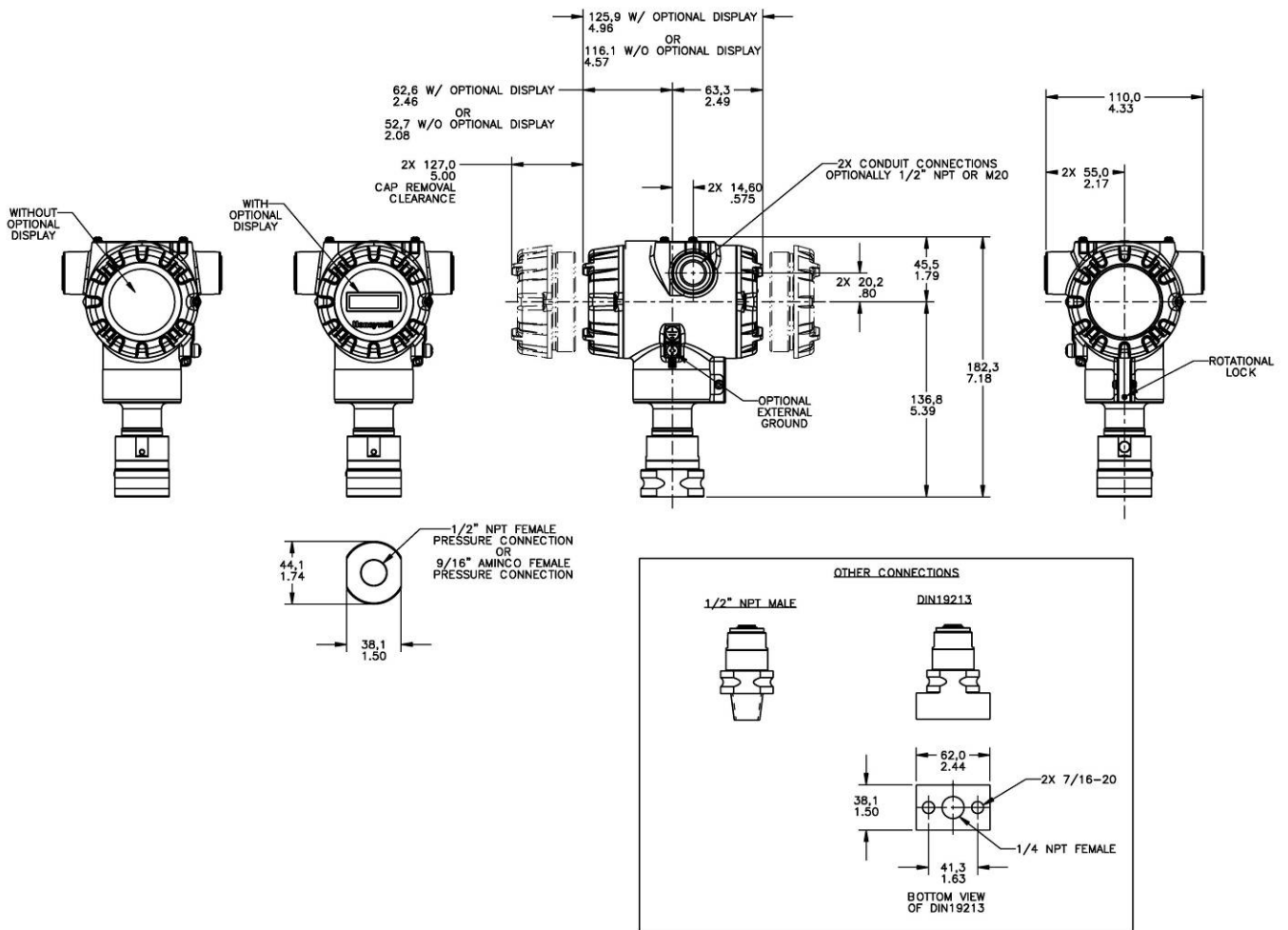

Figure 4– Typical mounting dimensions of STA72L & STA74L for reference



TABLE II Meter Body & Connection Orientation		
Head/Connect Orientation	Standard	High Side Left, Low Side Right ² / Std Head Orientation
	Reversed	Low Side Left, High Side Right ² / Std Head Orientation
	90/Standard	High Side Left, Low Side Right ² / 90 ⁰ Head Rotation

1	*	*
2	*	
3	h	

TABLE III AGENCY APPROVALS	
Approvals	No Approvals Required
	<FM> Explosion proof, Intrinsically Safe, Non-incendive, & Dustproof
	CSA Explosion proof, Intrinsically Safe, Non-incendive, & Dustproof
	ATEX Explosion proof, Intrinsically Safe & Non-incendive
	IECEX Explosion proof, Intrinsically Safe & Non-incendive
	SAEx Explosion proof, Intrinsically Safe & Non-incendive
	INMETRO Explosion proof, Intrinsically Safe & Non-incendive
	NEPSI Explosion proof, Intrinsically Safe & Non-incendive
	KOSHA Explosion proof, Intrinsically Safe & Non-incendive
	EAC Customs Union (Russia,Belarus,Kazakhstan) Ex Approval,Flame proof, Intrinsically Safe
	ATEX/IECEX Explosion proof, Intrinsically Safe & Non-incendive
	CCoE Explosion proof, Intrinsically Safe & Non-incendive
	UATR Flameproof, Intrinsically Safe & Dustproof

0	*	*
A	*	*
B	*	*
C	*	*
D	*	*
E	*	*
F	*	*
G	*	*
H	*	*
I	*	*
1	*	*
J	*	*
K	*	*

TABLE IV TRANSMITTER ELECTRONICS SELECTIONS			
a. Electronic Housing Material & Connection Type	Material	Connection	Lightning Protection
	Polyester Powder Coated Aluminum	1/2 NPT	None
	Polyester Powder Coated Aluminum	M20	None
	Polyester Powder Coated Aluminum	1/2 NPT	Yes
	Polyester Powder Coated Aluminum	M20	Yes
	Dual Certified SS 316/316L (CF8M/CF3M)	1/2 NPT	None
	Dual Certified SS 316/316L (CF8M/CF3M)	M20	None
	Dual Certified SS 316/316L (CF8M/CF3M)	1/2 NPT	Yes
	Dual Certified SS 316/316L (CF8M/CF3M)	M20	Yes
b. Output/ Protocol	Analog Output		Digital Protocol
	4-20mA dc 4-20mA dc		HART Protocol DE Protocol
c. Customer Interface Selections	Indicator	Ext Zero, Span & Config Buttons	Languages
	None	None	None
	None	Yes (Zero/Span Only)	None
	Advanced	None	EN, GE, FR, IT, SP, RU, TU
	Advanced	Yes	EN, GR, FR, IT, SP, RU, TU
	Advanced	None	EN, CH, JP
	Advanced	Yes	EN, CH, JP
	Standard (w/internal Zero, Span & Conf Buttons)	None	EN, RU
Standard (w/internal Zero, Span & Conf Buttons)	Yes	EN, RU	

A__	*	*
B__	*	*
C__	*	*
D__	*	*
E__	*	*
F__	*	*
G__	*	*
H__	*	*

H	*	*
D	*	*

__0	*	*
__A	*	*
__D	*	*
__E	*	*
__H	*	*
__J	*	*

__S	u	u
__T	u	u

TABLE V CONFIGURATION SELECTIONS			
a. App S/W	Diagnostics		
	Standard Diagnostics		
b. Output Limit, Failsafe & Write Protect Settings	Write Protect	Fail Mode	High & Low Output Limits ³
	Disabled	High> 21.0mAdc	Honeywell Std (3.8 - 20.8 mAdc)
	Disabled	Low< 3.6mAdc	Honeywell Std (3.8 - 20.8 mAdc)
	Enabled	High> 21.0mAdc	Honeywell Std (3.8 - 20.8 mAdc)
	Enabled	Low< 3.6mAdc	Honeywell Std (3.8 - 20.8 mAdc)
c. General Configuration	General Configuration		
	Factory Standard Customer Configuration (Unit Data Required)		

1__	*	*
-----	---	---

1	*	*
2	*	*
3	*	*
4	*	*

__S	*	*
__C	*	*

² Left side/Right side as viewed from the customer connection perspective

³ NAMUR Output Limits 3.8 - 20.5mAdc can be configured by the custom

TABLE VI CALIBRATION & ACCURACY SELECTIONS			
Accuracy and Calibration	Accuracy	Calibrated Range	Calibration Qty
	Standard	Factory Std	Single Calibration
	Standard	Custom (Unit Data Required)	Single Calibration
	High Accuracy	Factory Std	Single Calibration
	High Accuracy	Custom (Unit Data Required)	Single Calibration

STA72L
STA74L
STA72Z
STA740

A	*	*
B	*	*
E	s	s
F	s	s

TABLE VII ACCESSORY SELECTIONS		
	Bracket Type	Material
a. Mounting Bracket	None	None
	Angle Bracket	Carbon Steel
	Angle Bracket	304 SS
	Angle Bracket	316 SS
	Marine Approved Bracket	Carbon Steel
	Marine Approved Bracket(In-Line)	Carbon Steel
	Marine Approved Bracket	304 SS
	Marine Approved Bracket(In-Line)	304 SS
	Flat Bracket	Carbon Steel
	Flat Bracket	304 SS
Flat Bracket	316 SS	
b. Customer Tag	Customer Tag Type	
	No customer tag	
	One Wired Stainless Steel Tag (Up to 4 lines 26char/line)	
c. Unassembled Conduit Plugs & Adapters	Unassembled Conduit Plugs & Adapters	
	No Conduit Plugs or Adapters Required	
	1/2 NPT Male to 3/4 NPT Female 316 SS Certified Conduit Adapter	
	1/2 NPT 316 SS Certified Conduit Plug	
	M20 316 SS Certified Conduit Plug	
	Minifast [®] 4 pin (1/2 NPT) (not suitable for X-Proof applications)	
Minifast [®] 4 pin (M20) (not suitable for X-Proof applications)		

0 ---	*	*
1 ---	*	*
2 ---	*	*
3 ---	*	*
8 ---	*	*
9 ---	*	*
4 ---	*	*
A ---	*	*
5 ---	*	*
6 ---	*	*
7 ---	*	*
_0 ---	*	*
_1 ---	*	*
_2 ---	*	*
_A0	*	*
_A2	n	n
_A6	n	n
_A7	m	m
_A8	n	n
_A9	m	m

TABLE VIII OTHER Certifications & Options: (String in sequence comma delimited (XX,XX,XX,...))	
Certifications & Warranty	None - No additional options
	NACE MR0175; MR0103; ISO 15156 (FC33338) Process wetted parts only
	NACE MR0175; MR0103; ISO 15156 (FC33339) Process wetted and non-wetted parts
	Marine (DNV, ABS, BV, KR, LR)
	EN 10204 Type 3.1 Material Traceability (FC33341)
	Certificate of Conformance (F3391)
	Calibration Test Report & Certificate of Conformance (F3399)
	Certificate of Origin (F0195)
	FMEDA (SIL 2/3) Certification (FC33337)
	Over-Pressure Leak Test Certificate (1.5X MAWP) (F3392) for Transmitter Only
	Helium Leak Test for Transmitter Only
	Cert Clean for O ₂ or CL ₂ service per ASTM G93
	PMI Certification ¹
	Extended Warranty Additional 1 year for Transmitter Only
	Extended Warranty Additional 2 years for Transmitter Only
	Extended Warranty Additional 3 years for Transmitter Only
	Extended Warranty Additional 4 years for Transmitter Only
	Integrate Manifold with combined TP test for assembly
Detailed Manifold configuration required	
Integrate Manifold with combined Helium leak test for assembly	
Detailed Manifold configuration required	

00	*	*
FG	*	*
F7	c	c
MT	d	d
FX	*	*
F3	*	*
F1	*	*
F5	*	*
FE	j	j
TP	*	*
HT	*	*
OX	e	e
PM	*	*
01	*	*
02	*	*
03	*	*
04	*	*
MI	1	1
MH	1	1

*: TP combined test is carried out at 1.5 times of lowest pressure rating of any of the transmitter or the manifold

TABLE IX Manufacturing Specials	
Factory	Factory Identification

0000	*	*
------	---	---

RESTRICTIONS

Restriction Letter	Available Only with		Not Available with	
	Table	Selection(s)	Table	Selection(s)
a			VII	FG, F7
c	Id	0,N,K,D,B	Ia	D,H,K,L
d	IVa	C,D,G,H	VIa	1,2,3,5,6,7
e	Ib	2		
h			VIe	4,5,6
j	IVb	H	VIa	1,2,3,4,5,6,7,8
m	IVa	B,D,F,H	Vb	1,2
n	IVa	A,C,E,G		
p			III	B - No CRN number available
s	Ia	A,E		
t			1a	J,K,L
u	IVb	H		
1			VII	TP,HT
b	Select Only one option from this group			

¹The PM option is available on all Smartline Pressure Transmitter process wetted parts such as process heads, flanges, bushings and vent plugs except plated carbon steel process heads and flanges. PM option information is also available on diaphragms except STG and STA in-line construction pressure transmitters.

FIELD INSTALLABLE ACCESSORY KITS

Description	Kit Number
Integrally Mounted Advanced Indicator Kit (compatible with all Electronic Modules)	50049846-501
Standard Display Module	50126003-501
Terminal Strip w/ Lightning Protection Kit for HART, DE, or HART/DE Modules	50075472-532
Terminal Strip w/ Lightning Protection Kit for FFB Module	50075472-534
Terminal Strip w/o Lightning Protection for HART, DE, or HART/DE Module	50075472-531
Terminal Strip w/o Lightning Protection FFB Module	50075472-533
HART Electronics Module	50049849-501
HART Electronics Module w/ connection for external configuration buttons	50049849-502
DE Electronics Module	50049849-503
DE Electronics Module w/ connection for external configuration buttons	50049849-504
FFB Electronics Module Kit	50049849-509
FFB Electronics Module w/ connection for external configuration buttons	50049849-510

Note P - For part number pricing please refer to E-Commerce portal.

PRODUCT MANUALS

Description	Part Number
ST 700 Smart Transmitter User Manual - English	34-ST-25-44
ST 700 Smart Transmitter HART/DE Communications Manual - English	34-ST-25-47
ST 700 Smart Transmitter Safety Manual - English	34-ST-25-37
ST 700 Smart Transmitter Foundation Fieldbus Manual - English	34-ST-25-48
ST 700 Smart Transmitter Function Block Manual - English	34-ST-25-49

Note P - For part number pricing please refer to the parts price book.

All product documentation is available at www.honeywellprocess.com.

Sales and Service

For application assistance, current specifications, ordering, pricing, and name of the nearest Authorized Distributor, contact one of the offices below.

ASIA PACIFIC

Honeywell Process Solutions,
Phone: + 800 12026455 or
+44 (0) 1202645583
(TAC) hfs-tac-support@honeywell.com

Australia

Honeywell Limited
Phone: +(61) 7-3846 1255
FAX: +(61) 7-3840 6481
Toll Free 1300-36-39-36
Toll Free Fax:
1300-36-04-70

China – PRC - Shanghai

Honeywell China Inc.
Phone: (86-21) 5257-4568
Fax: (86-21) 6237-2826

Singapore

Honeywell Pte Ltd.
Phone: +(65) 6580 3278
Fax: +(65) 6445-3033

South Korea

Honeywell Korea Co Ltd
Phone: +(822) 799 6114
Fax: +(822) 792 9015

EMEA

Honeywell Process Solutions,
Phone: + 800 12026455 or
+44 (0) 1202645583

Email: (Sales)

FP-Sales-Apps@Honeywell.com

or

(TAC)

hfs-tac-support@honeywell.com

Web

Knowledge Base search
engine <http://bit.ly/2N5Vldi>

AMERICAS

Honeywell Process Solutions,
Phone: (TAC) (800) 423-9883
or (215) 641-3610
(Sales) 1-800-343-0228

Email: (Sales)

FP-Sales-Apps@Honeywell.com

or

(TAC)

hfs-tac-support@honeywell.com

Web

Knowledge Base search
engine <http://bit.ly/2N5Vldi>

Specifications are subject to change without notice

For more information

To learn more about SmartLine Transmitters,
visit www.process.honeywell.com
Or contact your Honeywell Account Manager

Process Solutions

Honeywell
1250 W Sam Houston Pkwy S
Houston, TX 77042

Honeywell Control Systems Ltd
Honeywell House, Skimped Hill Lane
Bracknell, England, RG12 1EB

Shanghai City Centre, 100 Jungi Road
Shanghai, China 20061

www.process.honeywell.com



34-ST-03-100
December 2025

©2025 Honeywell International Inc.